

# HALE - FLEX

EXPANSION JOINTS

CONNECTORS

BELLOWS

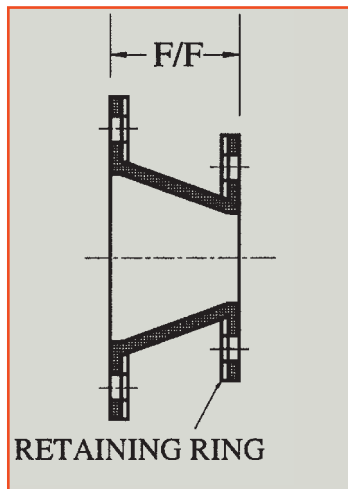
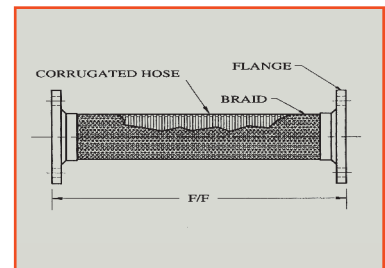
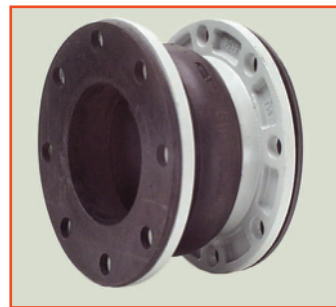

A WIDE SELECTION OF MATERIALS & MODELS

**HALE-FLEX** expansion joints / connectors / bellows have been used in the following industries under diverse application conditions:

- Cement
- Metallurgical
- Chemical
- Mining
- General Industrial
- Municipal
- HVAC
- Petroleum
- Laboratories
- Pulp and Paper
- Marine
- Power Generation
- Water Treatment

Expansion joints / connectors / bellows are used to absorb one or a combination of the following movements of the associated piping, machinery and equipment.

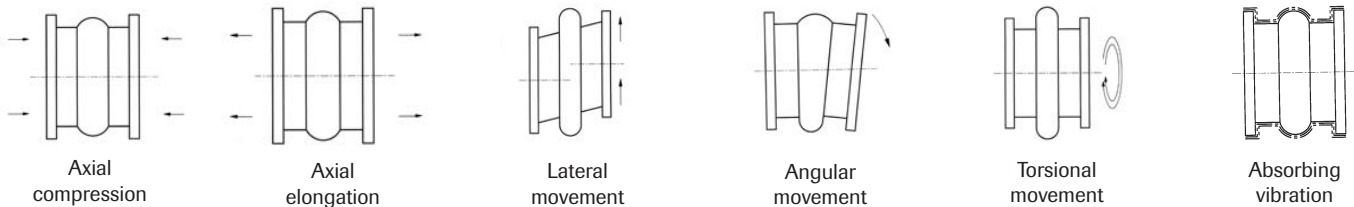

A **HALESON** representative will assist you in selecting one of the below HALE-FLEX models to suit your application.

**MODEL: HS-10R** SINGLE ARCH EXPANSION JOINT, C/W FLOATING FLANGES

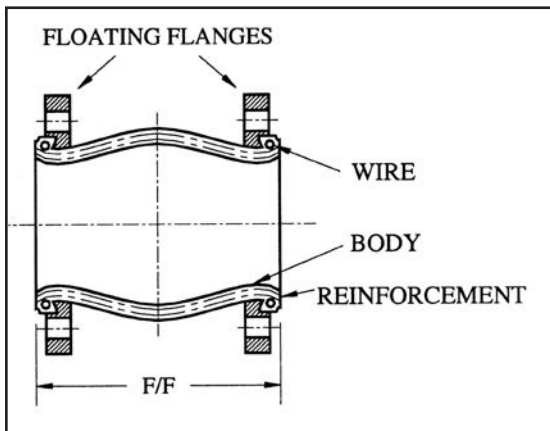

AVAILABILITY		
DESCRIPTION	STANDARD	SPECIAL
BODY	EPDM	NEOPRENE, BUNA-N CHLOROBUTYL ETC..
REINFORCING	NYLON TYRE CORD	N/A
WIRE	HARD STEEL WIRE	N/A
FLANGE MATERIAL	MILD STEEL ZINC PLATED	SS, BRONZE, MONEL
FLANGE STANDARD	ANSI 150 LB DRILLING	ANSI 300 LB DRILLING DIN, BS, JIS, ETC...
CONTROL RODS	NOT INCLUDED	AVAILABLE

**DATA FOR STANDARD MODEL HS-10R-EPDM**

Joint Size ID (in)	Face to Face F/F (in)	Allowable Movement (in) (1)				Operating Conditions (2) (3)		
		Axial Compression	Axial Elongation	Transverse Deflection	Angular Deflection	Max. Pressure PSIG @70°F	Max. Temperature °F @ 25PSIG	Vacuum Rating Hg in @70°F
1	6	1/2	3/8	±1/2	15°	225	300	16
1 1/2	6	1/2	3/8	±1/2	15°	225	300	16
2	6	1/2	3/8	±1/2	15°	225	300	16
2 1/2	6	1/2	3/8	±1/2	15°	225	300	16
3	6	1/2	3/8	±1/2	15°	225	300	16
4	6	5/8	3/8	±1/2	15°	225	300	16
5	6	5/8	3/8	±1/2	15°	225	300	16
6	6	5/8	3/8	±1/2	15°	225	300	16
8	6	3/4	3/8	±1/2	15°	225	300	16
10	8	3/4	1/2	±3/4	15°	225	300	16
12	8	1	1/2	±3/4	15°	225	300	16
14	8	1	5/8	±7/8	15°	150	300	16
16	8	1	5/8	±7/8	15°	125	300	16
18	8	1	5/8	±7/8	15°	125	300	16
20	8	1	5/8	±7/8	15°	125	300	16

Note: 1 - Allowable movements are non-concurrent, some applications may require control rods.  
 2 - Based on air as fluid. For other fluids consult your representative.  
 3 - Full vacuum option available. Consult your representative.



**MODEL: HS-20 DOUBLE ARCH EXPANSION JOINT, C/W FLOATING FLANGES**

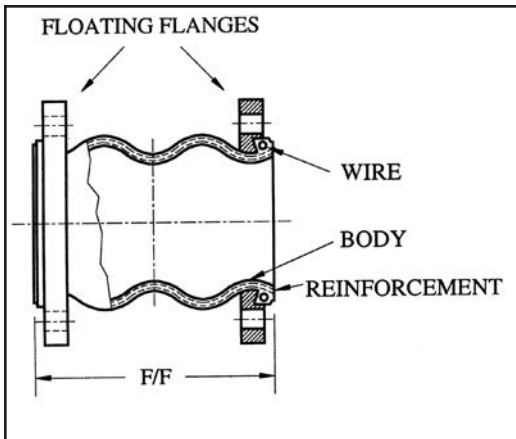

AVAILABILITY		
DESCRIPTION	STANDARD	SPECIAL
BODY	EPDM	NEOPRENE, BUNA-N CHLOROBUTYL ETC...
REINFORCING	NYLON TYRE CORD	N/A
FLANGE MATERIAL	MILD STEEL ZINC PLATED	SS, BRONZE, MONEL
FLANGE STANDARD	ANSI 150 LB DRILLING	ANSI 300 LB DRILLING DIN, BS, JIS, ETC...
CONTROL RODS	NOT INCLUDED	AVAILABLE

**DATA FOR STANDARD MODEL HS-20-EPDM**

Joint Size ID (in)	Face to Face F/F (in)	Allowable Movement (in) (1)				Operating Conditions (2) (3)		
		Axial Compression	Axial Elongation	Transverse Deflection	Angular Deflection	Max. Pressure PSIG @70°F (4)	Max. Temperature °F @ 25PSIG	Vacuum Rating Hg in @70°F
1 1/4	7	1 3/4	3/4	±1	40°	150	300	16
1 1/2	7	1 3/4	3/4	±1	40°	150	300	16
2	7	1 3/4	3/4	±1	40°	150	300	16
2 1/2	7	1 3/4	3/4	±1	40°	150	300	16
3	7	1 3/4	3/4	±1	40°	150	300	16
4	9	2	1	±1 1/4	40°	150	300	16
5	9	2	1	±1 1/4	35°	150	300	16
6	9	2	1	±1 1/4	35°	150	300	16
8	13	2 1/4	1	±1 1/4	30°	150	300	16
10	13	2 1/4	1	±1 1/4	30°	150	300	16
12	13	2 1/4	1	±1 1/4	30°	150	300	16
14	14	2	1	±1 1/4	20°	150	300	16
16	14	2	1	±1 1/4	20°	150	300	16
18	14	2	1	±1 1/4	20°	150	300	16

- Note: 1 - Allowable movements are non-concurrent, some applications may require control rods.  
 2 - Based on air as fluid. For other fluids consult your representative.  
 3 - Full vacuum option available. Consult your representative.  
 4 - 225 psig option is available.

## MODEL: HS-30-U DOUBLE SPHERE EXPANSION JOINT, C/W NPT THREADED UNIONS

AVAILABILITY		
DESCRIPTION	STANDARD	SPECIAL
BODY	EPDM	NEOPRENE, BUNA-N CHLOROBUTYL ETC..
REINFORCING	NYLON TYRE CORD	N/A
UNION MATERIAL	DUCTILE IRON GALVANIZED OR ZINC PLATED	STAINLESS STEEL

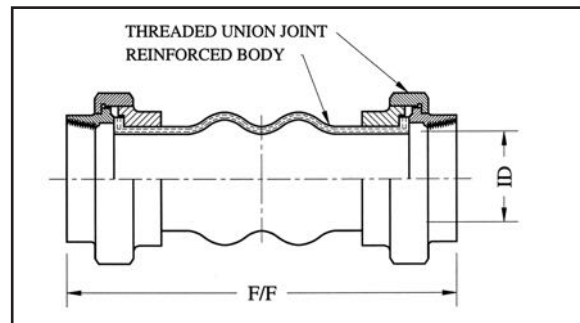

### DATA FOR STANDARD MODEL H-S30-U-EPDM

Joint Size ID (in)	Face to Face F/F (in)	Allowable Movement (in) (1)				(2) (3)		
		Axial Compression	Axial Elongation	Transverse Deflection	Angular Deflection	Max. Pressure PSIG @70°F	Max. Temperature °F @ 25PSIG	Vacuum Rating Hg in @70°F
3/4	8	7/8	1/4	±7/8	45°	150	300	16
1	8	7/8	1/4	±7/8	45°	150	300	16
1 1/4	8	7/8	1/4	±7/8	45°	150	300	16
1 1/2	8	7/8	1/4	±7/8	45°	150	300	16
2	8	7/8	1/4	±7/8	45°	150	300	16
2 1/2	8	7/8	1/4	±7/8	45°	150	300	16
3	8	7/8	1/4	±7/8	45°	150	300	16

- Note: 1 - Allowable movements are non-concurrent, some applications may require control rods.  
 2 - Based on air as fluid. For other fluids consult your representative.  
 3 - Full vacuum option available. Consult your representative.

## MODEL: HS-21-SP SINGLE ARCH STANDARD PRESSURE EXPANSION JOINT, C/W RETAINING RINGS

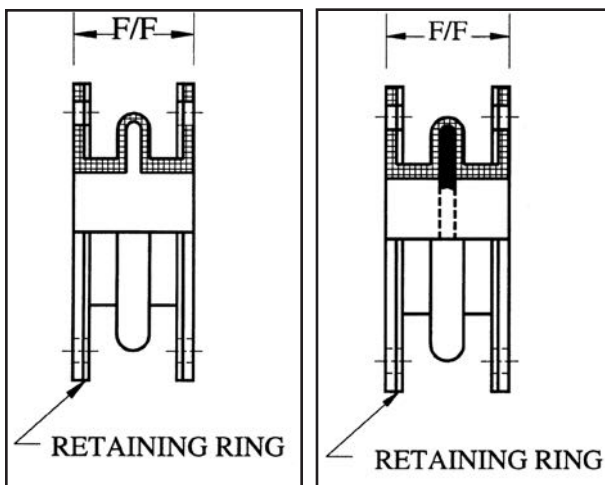

AVAILABILITY		
DESCRIPTION	STANDARD	SPECIAL
BODY	EPDM (TUBE AND COVER)	NEOPRENE, BUNA-N CHLOROBUTYL ETC..
ARCH	REGULAR	FILLED MODEL H-S21-FA
FLANGES	FULL FACE ANSI 150 LB DRILLING	ANSI 300 LB DRILLING DIN, BS, JIS , ETC...
RETAINING RINGS MATERIAL	MILD STEEL GALVANIZED OR PAINTED	SS, BRONZE, MONEL
CONTROL RODS	NOT INCLUDED	AVAILABLE
SIZES	UP TO 36 IN	UP TO 84 IN

## MODEL: HS-2N MULTIPLE ARCH EXPANSION JOINT, C/W RETAINING RINGS

Examples: HS-22 For Double Arch; HS-23 For Triple Arch etc...

AVAILABILITY		
DESCRIPTION	STANDARD	SPECIAL
BODY	EPDM (TUBE AND COVER)	NEOPRENE, BUNA-N CHLOROBUTYL ETC...
ARCH	REGULAR	FILLED
FLANGES	FULL FACE ANSI 150 LB DRILLING	ANSI 300 LB DRILLING DIN, BS, JIS , ETC...
RETAINING RINGS MATERIAL	MILD STEEL GALVANIZED OR PAINTED	SS, BRONZE, MONEL
SIZES	UP TO 36 IN	UP TO 84 IN

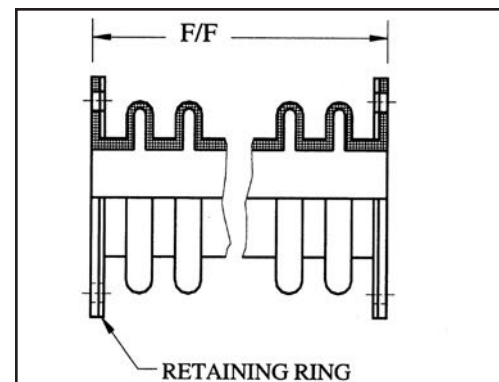

MODEL: HS-60 WIDE ARCH EXPANSION JOINT, C/W RETAINING RINGS

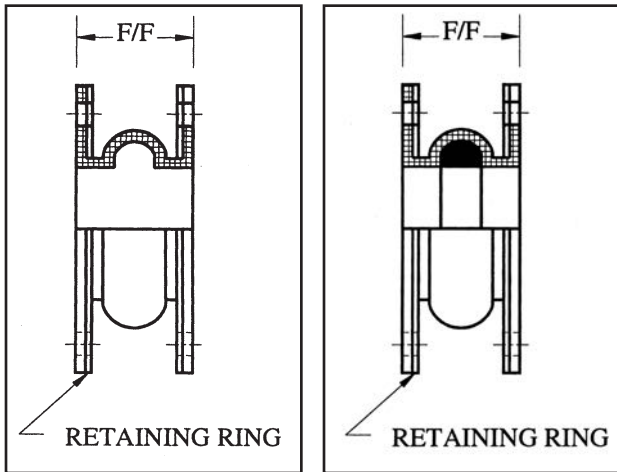

AVAILABILITY		
DESCRIPTION	STANDARD	SPECIAL
BODY	EPDM (TUBE AND COVER)	NEOPRENE, BUNA-N CHLOROBUTYL ETC...
ARCH	WIDE	FILLED MODEL H-S60-FA
FLANGES	FULL FACE ANSI 150 LB DRILLING	ANSI 300 LB DRILLING DIN, BS, JIS , ETC...
RETAINING RINGS MATERIAL	MILD STEEL GALVANIZED OR PAINTED	SS, BRONZE, MONEL
CONTROL RODS	NOT INCLUDED	AVAILABLE

DATA FOR STANDARD MODEL HS-60-EPDM

Joint Size ID (in)	Face to Face F/F (in)	Allowable Movement (in) (1)				Operating Conditions (2) (3)		
		Axial Compression	Axial Elongation	Transverse Deflection	Angular Deflection	Max. Pressure PSIG @70°F	Max. Temperature °F @ 25PSIG	Vacuum Rating Hg in @70°F
2	6	1 3/4	3/4	3/4	35°	150	300	15
2 1/2	6	1 3/4	3/4	3/4	30°	150	300	15
3	6	1 3/4	3/4	3/4	30°	150	300	15
4	6	1 3/4	3/4	3/4	25°	150	300	15
5	6	1 3/4	3/4	3/4	25°	150	300	15
6	6	1 3/4	3/4	1	20°	150	300	15
8	6	1 3/4	3/4	1	20°	150	300	15
10	8	1 3/4	3/4	1	15°	150	300	15
12	8	1 3/4	3/4	1	15°	150	300	15
14	8	2	7/8	1 1/8	12°	130	300	10
16	8	2	7/8	1 1/8	12°	110	300	10
18	8	2	7/8	1 1/8	9°	110	300	10
20	8	2	7/8	1 1/8	9°	110	300	10
24	10	2 1/4	1	1 1/8	9°	100	300	10

Note: 1 - Allowable movements are non-concurrent, some applications may require control rods.  
 2 - Based on air as fluid. For other fluids consult your representative.  
 3 - Full vacuum option available. Consult your representative.



**MODEL: HS-60-BV** LIGHT WEIGHT WIDE ARCH EXPANSION JOINT FOR BLOWERS AND VACUUM PUMPS, C/W RETAINING RINGS

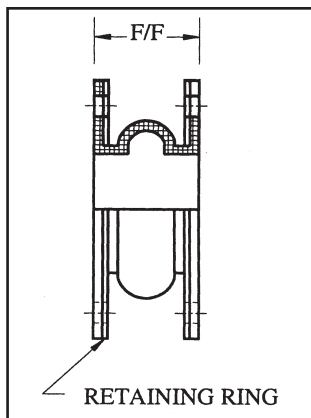

AVAILABILITY		
DESCRIPTION	STANDARD	SPECIAL
BODY	EPDM (TUBE AND COVER)	NEOPRENE, BUNA-N CHLOROBUTYL ETC...
ARCH	WIDE	N/A
FLANGES	FULL FACE ANSI 150 LB DRILLING	ANSI 300 LB DRILLING DIN, BS, JIS , ETC...
RETAINING RINGS MATERIAL	MILD STEEL GALVANIZED OR PAINTED	SS, BRONZE, MONEL
CONTROL RODS	NOT INCLUDED	AVAILABLE

**DATA FOR STANDARD MODEL HS-60-BV-EPDM**

Joint Size ID (in)	Face to Face F/F (in)	Allowable Movement (in) (1)				Operating Conditions (2) (3)		
		Axial Compression	Axial Elongation	Transverse Deflection	Angular Deflection	Max. Pressure PSIG @70°F	Max. Temperature °F @ 25PSIG	Vacuum Rating Hg in @70°F
2	6	1 3/4	3/4	3/4	35°	25	300	26
2 1/2	6	1 3/4	3/4	3/4	30°	25	300	26
3	6	1 3/4	3/4	3/4	30°	25	300	26
4	6	1 3/4	3/4	3/4	25°	25	300	26
5	6	1 3/4	3/4	3/4	25°	25	300	26
6	6	1 3/4	3/4	1	20°	25	300	26
8	6	1 3/4	3/4	1	20°	25	300	26
10	8	1 3/4	3/4	1	15°	25	300	26
12	8	1 3/4	3/4	1	15°	25	300	26
14	8	2	7/8	1 1/8	12°	25	300	26
16	8	2	7/8	1 1/8	12°	25	300	26
18	8	2	7/8	1 1/8	9°	25	300	26
20	8	2	7/8	1 1/8	9°	25	300	26
24	10	2 1/4	1	1 1/8	9°	25	300	26

Note: 1 - Allowable movements are non-concurrent, some applications may require control rods.

2 - Based on air as fluid. For other fluids consult your representative.

3 - Full vacuum option available. Consult your representative.

**MODEL: HS-21-HP** HIGH PRESSURE OR NAVY EXPANSION JOINT, C/W RETAINING RINGS

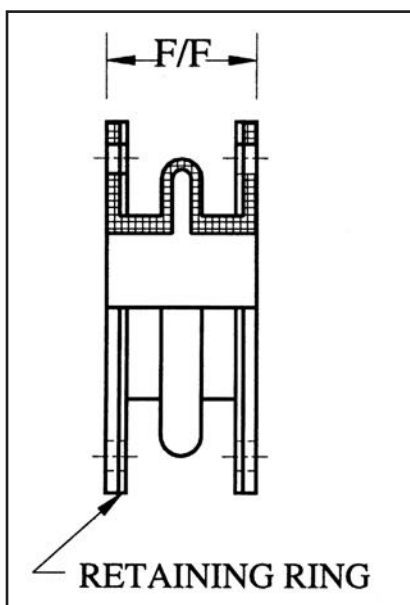

AVAILABILITY		
DESCRIPTION	STANDARD	SPECIAL
BODY	EPDM (TUBE AND COVER)	NEOPRENE, BUNA-N CHLOROBUTYL ETC...
ARCH	REGULAR SINGLE	FILLED MULTIPLE
FLANGES	FULL FACE ANSI 150 LB DRILLING	ANSI 300 LB DRILLING DIN, BS, JIS , ETC...
RETAINING RINGS MATERIAL	MILD STEEL GALVANIZED OR PAINTED	SS, BRONZE, MONEL
CONTROL RODS	NOT INCLUDED	AVAILABLE
SIZES	UP TO 36 IN	UP TO 84 IN
PRESSURES	UP TO 350 PSIG DEPENDING ON JOINT SIZE	UP TO 350 PSIG DEPENDING ON JOINT SIZE

**MODEL: HS-SE-21 SINGLE ARCH SLEEVE TYPE CONNECTORS**

AVAILABILITY		
DESCRIPTION	STANDARD	SPECIAL
BODY	EPDM (TUBE AND COVER)	NEOPRENE, BUNA-N CHLOROBUTYL ETC...
ARCHES	SINGLE	MULTIPLE
HOSE CLAMPS	NOT INCLUDED	AVAILABLE

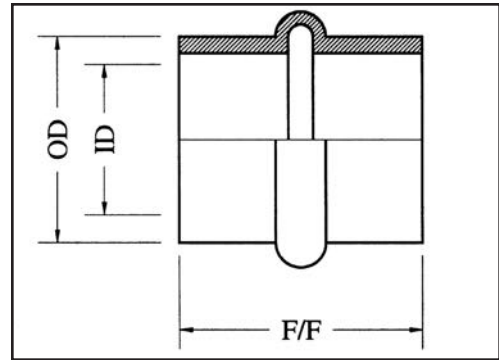

**MODEL: HS-CR-21 CONCENTRIC REDUCER SINGLE ARCH, C/W RETAINING RINGS**

AVAILABILITY		
DESCRIPTION	STANDARD	SPECIAL
BODY	EPDM (TUBE AND COVER)	NEOPRENE, BUNA-N CHLOROBUTYL ETC..
FLANGES	FULL FACE ANSI 150 LB DRILLING	ANSI 300 LB DRILLING DIN, BS, JIS , ETC...
RETAINING RINGS MATERIAL	MILD STEEL GALVANIZED OR PAINTED	SS, BRONZE, MONEL
CONTROL RODS	NOT INCLUDED	AVAILABLE

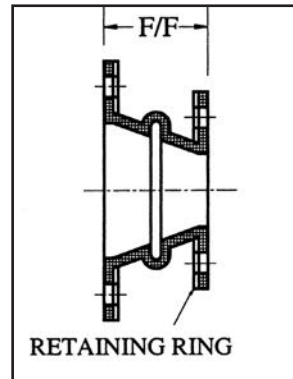

**MODEL: HS-ER-21 ECCENTRIC REDUCER SINGLE ARCH, C/W RETAINING RINGS**

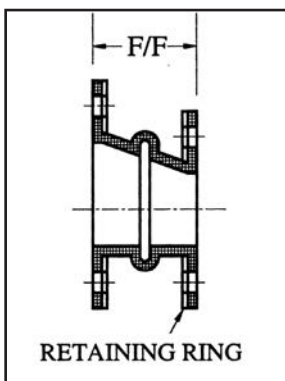

AVAILABILITY		
DESCRIPTION	STANDARD	SPECIAL
BODY	EPDM (TUBE AND COVER)	NEOPRENE, BUNA-N CHLOROBUTYL ETC...
FLANGES	FULL FACE ANSI 150 LB DRILLING	ANSI 300 LB DRILLING DIN, BS, JIS , ETC...
RETAINING RINGS MATERIAL	MILD STEEL GALVANIZED OR PAINTED	SS, BRONZE, MONEL
CONTROL RODS	NOT INCLUDED	AVAILABLE

**MODEL: HS-PC-15 CONCENTRIC PUMP CONNECTOR, C/W RETAINING RINGS**

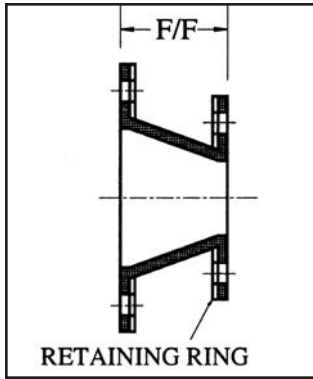

AVAILABILITY		
DESCRIPTION	STANDARD	SPECIAL
BODY	EPDM	NEOPRENE, BUNA-N CHLOROBUTYL ETC...
FLANGES	FULL FACE ANSI 150 LB DRILLING	ANSI 300 LB DRILLING DIN, BS, JIS , ETC...
RETAINING RINGS MATERIAL	MILD STEEL GALVANIZED OR PAINTED	SS, BRONZE, MONEL
CONTROL RODS	NOT INCLUDED	AVAILABLE

**MODEL: HS-PC-25 ECCENTRIC PUMP CONNECTOR, C/W RETAINING RINGS**

AVAILABILITY		
DESCRIPTION	STANDARD	SPECIAL
BODY	EPDM	NEOPRENE, BUNA-N CHLOROBUTYL ETC...
FLANGES	FULL FACE ANSI 150 LB DRILLING	ANSI 300 LB DRILLING DIN, BS, JIS , ETC...
RETAINING RINGS MATERIAL	MILD STEEL GALVANIZED OR PAINTED	SS, BRONZE, MONEL
CONTROL RODS	NOT INCLUDED	AVAILABLE

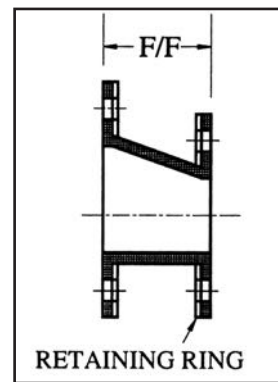

**MODEL: HS-PC-50 PUMP CONNECTOR, C/W RETAINING RINGS**

AVAILABILITY		
DESCRIPTION	STANDARD	SPECIAL
BODY	EPDM	NEOPRENE, BUNA-N CHLOROBUTYL ETC...
FLANGES	FULL FACE ANSI 150 LB DRILLING	ANSI 300 LB DRILLING DIN, BS, JIS , ETC...
RETAINING RINGS MATERIAL	MILD STEEL GALVANIZED OR PAINTED	SS, BRONZE, MONEL
CONTROL RODS	NOT INCLUDED	AVAILABLE
SIZES	UP TO 36 IN	UP TO 84 IN
F/F LENGTH	12 IN, 18 IN, 24 IN	AS PER CUSTOMER REQUIREMENT

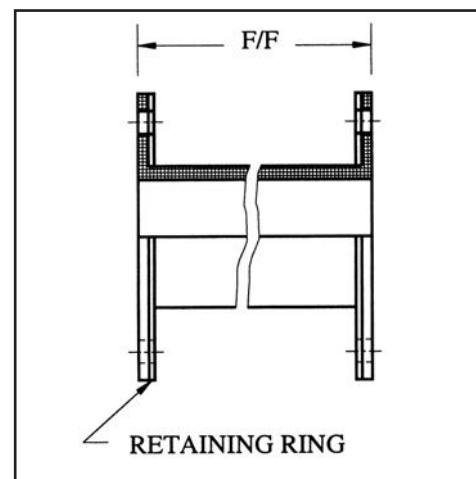



MODEL: HS-TE-21 PTFE LINED SINGLE ARCH EXPANSION JOINT, C/W RETAINING RINGS

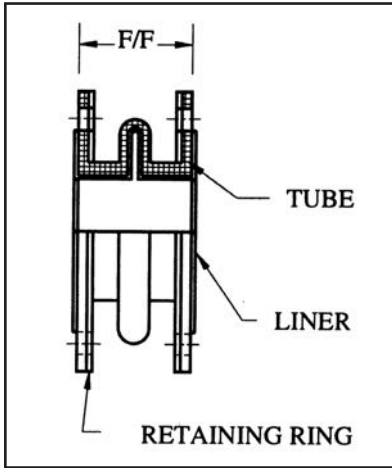

AVAILABILITY		
DESCRIPTION	STANDARD	SPECIAL
BODY	PTFE LINER EPDM COVER	LINERS IN: FEP, PFA TUBE AND COVERS IN: NEOPRENE, BUNA-N CHLOROBUTYL ETC...
ARCH	SINGLE	MULTIPLE
FLANGES	FULL FACE ANSI 150 LB DRILLING	ANSI 300 LB DRILLING DIN, BS, JIS , ETC...
RETAINING RINGS MATERIAL	MILD STEEL GALVANIZED OR PAINTED	SS, MONEL
CONTROL RODS	NOT INCLUDED	AVAILABLE

MODEL: HS-BS-W BRAIDED CONNECTOR, C/W WELD ENDS

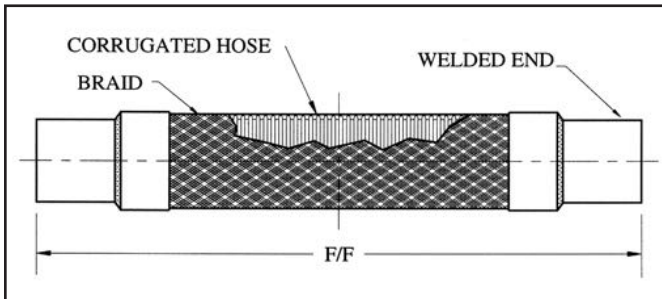

SPECIFICATIONS		
DESCRIPTION	STANDARD	SPECIAL
HOSE	SS 304 OR 321	SS 316, MONEL, BRONZE
BRAID	SS 304	SS 316, MONEL, BRONZE
WELD END NIPPLE	CARBON STEEL	SS, MONEL, BRONZE COPPER
NIPPLE SCHEDULE	SCHEDULE 40	SCHEDULE 80

AVAILABLE DIMENSIONS		
JOINT SIZE ID (in)	STANDARD	SPECIAL
	F/F LENGTH (in)	F/F LENGTH (in)
1/2	AS PER CUSTOMER REQUIREMENT	AS PER CUSTOMER REQUIREMENT
3/4		
1		
1 1/4		
1 1/2		
2		
2 1/2		
3		
4		

**MODEL: HS-BS-NPT BRAIDED CONNECTOR, C/W NPT ENDS**

SPECIFICATIONS		
DESCRIPTION	STANDARD	SPECIAL
HOSE	SS 304 OR 321	SS 316, MONEL, BRONZE
BRAID	SS 304	SS 316, MONEL, BRONZE
MALE NPT	CARBON STEEL	SS, MONEL, BRONZE

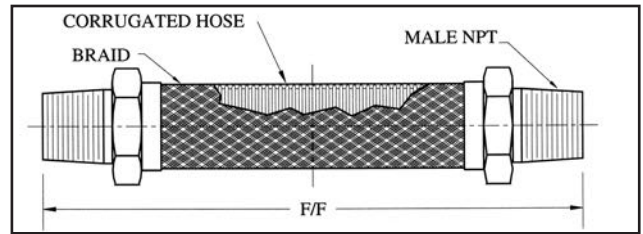

AVAILABLE DIMENSIONS		
JOINT SIZE ID (in)	STANDARD	SPECIAL
	F/F LENGTH (in)	F/F LENGTH (in)
1/2	6, 12, 18, 24, 36, 48	AS PER CUSTOMER REQUIREMENT
3/4	6, 12, 18, 24, 36, 48	
1	12, 18, 24, 36, 48	
1 1/4	12, 18, 24, 36, 48	
1 1/2	12, 18, 24, 36, 48	
2	12, 18, 24, 36, 48	
2 1/2	AS PER CUSTOMER REQUIREMENT	
3	AS PER CUSTOMER REQUIREMENT	
4	AS PER CUSTOMER REQUIREMENT	

Note: Model NPT with hex nut shown for illustration. Other fittings are also available.  
CSA / UL / CRN Approved connectors are also available.

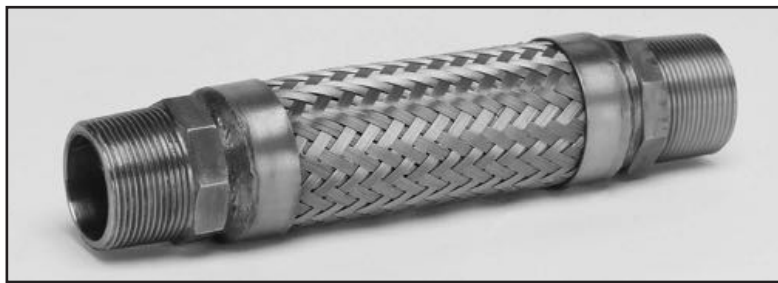

**MODEL: HS-BS-FF BRAIDED CONNECTOR, C/W FLAT FACE FLANGES**

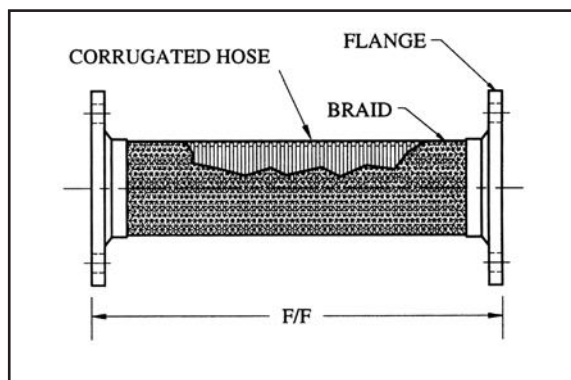

SPECIFICATIONS		
DESCRIPTION	STANDARD	SPECIAL
	SS 304 OR 321	SS 316, MONEL, BRONZE
	SS 304	SS 316, MONEL, BRONZE
	CARBON STEEL FLAT FACE	SS, MONEL, BRONZE

AVAILABLE DIMENSIONS		
JOINT SIZE ID (in)	STANDARD	SPECIAL
	F/F LENGTH (in)	F/F LENGTH (in)
1	8, 12	AS PER CUSTOMER REQUIREMENT
1 1/4	8, 12	
1 1/2	8, 12	
2	8, 12	
2 1/2	8, 12	
3	8, 12	
4	12, 15	
5	12	
6	12, 15, 18	
LARGER SIZES ALSO AVAILABLE		

**MODEL: HS-BS-RF BRAIDED CONNECTOR, C/W RAISED FACE FLANGES**

SPECIFICATIONS		
SS 304 OR 321	SS 316, MONEL, BRONZE	
SS 304	SS 316, MONEL, BRONZE	
CARBON STEEL	SS, MONEL, BRONZE RAISED FACE	

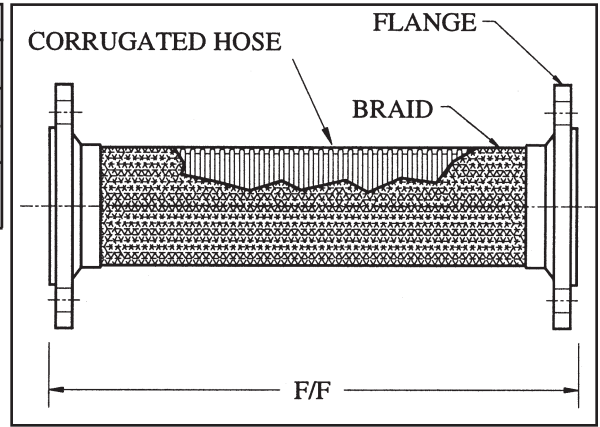

AVAILABLE DIMENSIONS		
JOINT SIZE ID (in)	STANDARD F/F LENGTH (in)	SPECIAL F/F LENGTH (in)
1	8, 12	AS PER CUSTOMER REQUIREMENT
1 1/4	8, 12	
1 1/2	8, 12	
2	8, 12	
2 1/2	8, 12	
3	8, 12	
4	12, 15	
5	12	
6	12, 15, 18	
LARGER SIZES AVAILABLE		

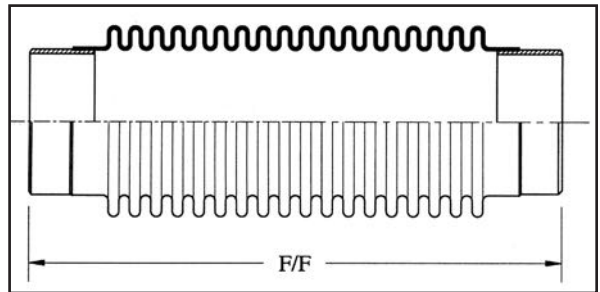

**MODEL: HS-BE BELLOWS TYPE EXPANSION JOINT**

AVAILABILITY	
CORRUGATION DENSITY	LOW, MID, HIGH
BELLOWS MATERIAL	SS 321, SS 304, SS316, SS316L, BRONZE, MONEL, INCONNEL ETC...
CONNECTION TYPE	WELD ENDS FLAT FACE FLANGED RAISED FACE FLANGED FLOATING FLANGED OR ANY COMBINATION OF THE ABOVE
FLANGE TYPE	ANSI 150 LB ANSI 300 LB DIN, BS, JIS , ETC...
FLANGE MATERIAL	CARBON STEEL, SS, BRONZE, MONEL, INCONNEL
SIZE RANGE	1 IN TO 108 IN
PRESSURE RANGE	VACUUM TO 1000 PSIG (Depending on size, materials, model and temperature)
TEMPERATURE RANGE	-20 F TO 800F (Depending on size, materials, model and pressure)
OPTIONS	INTERNAL LINER CONTROL RODS MULTI-PLY BELLOWS

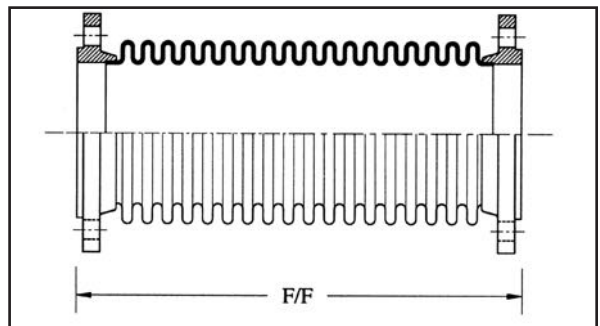
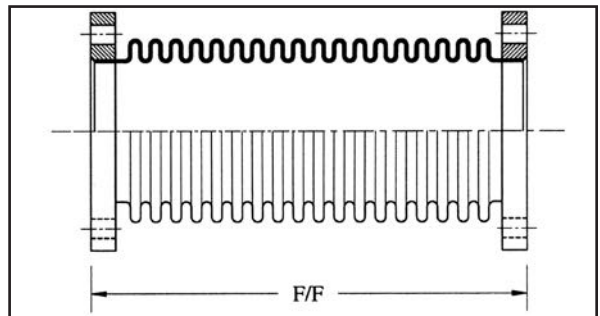

HALESON provides a limited guarantee up to 12 months from date of shipping of all its goods and products against defects of faulty manufacturing or materials or design.

HALESON warrants that any product sold by HALESON which upon inspection by a HALESON representative is found to be defective either in manufacturing or material or design and found not to be suitable for the purpose it was bought for, will be, at HALESON's option, repaired or replaced free of charge without including transportation costs provided that, HALESON receives written claim specifying the defect within 12 months after HALESON ships the product.

Claims for labour costs and other expenses required to replace such defective product or to repair damage resulting from the use thereof will not be allowed by HALESON.

HALESON's liability is limited to the price paid for the defective product. ALL OTHER WARRANTIES EXPRESSED AND IMPLIED ARE HEREBY DISCLAIMED. UNDER NO CIRCUMSTANCES HALESON SHALL BE LIABLE FOR CONSEQUENTIAL DAMAGES.

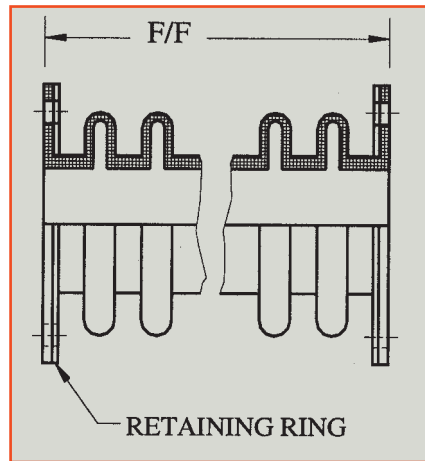
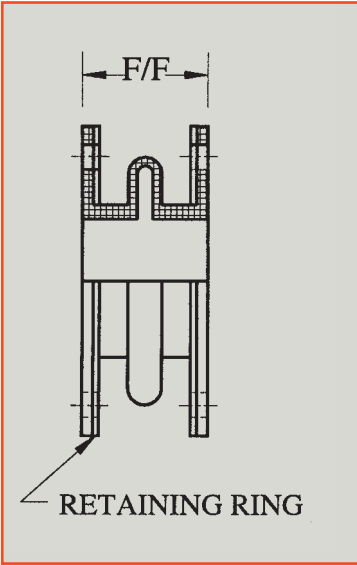

HALESON  
Montréal

Tel.: (450) 686-6663  
Fax: (450) 686-7776  
www.halesoninc.com

Houston

Tel.: (281) 548-7100  
Fax: (281) 548-7101

IN YOUR AREA DISTRIBUTED BY: