



TITLE:
Angle Type Strainer Plate & Screen

304/316L

Sanitaire / Biopharma / Industriel

SIZE: A DRAWING NO. HS-ANGLE-STRAINER-PS REV 0

WWW.HALESONINC.COM
Tel. (450) 686-6663 Fax. (450) 686-7776

DATE: 22 JANUARY 2020 SHEET 1 OF 1

SCALE: NONE

DATE: 22 JANUARY 2020

SHEET 1 OF 1

Clamped Angle Type Strainer

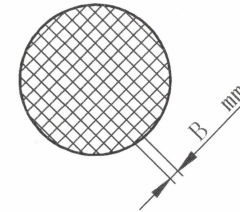
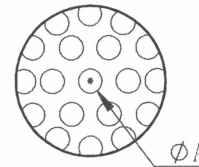
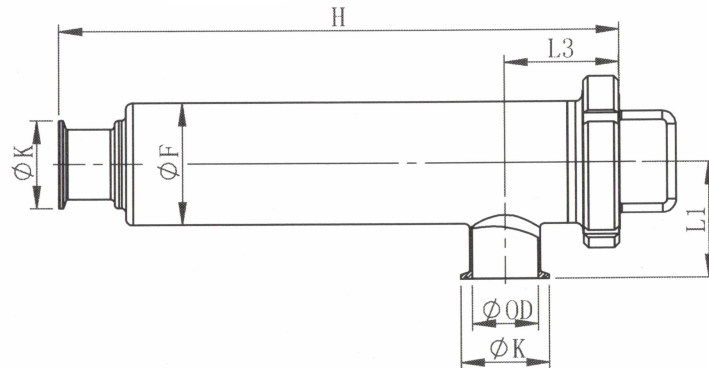

Welded angle-type Strainer

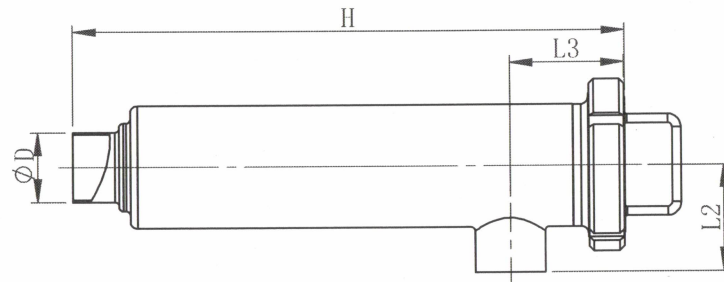

ANGLE FILTER INTERNAL

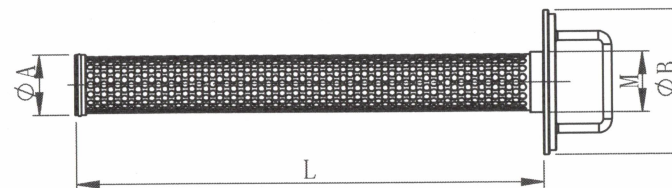

Screen: Metal Mesh

MESH	B (mm)	USEFUL SURFACE (%)
30	0.55	48.0
40	0.40	46.0
60	0.30	52.6
80	0.20	42.0
100	0.15	36.2
165	0.10	45.5

Screen: Perforated Mesh

	A (mm)	USEFUL SURFACE (%)
	0.5	15
	1.0	28
	1.5	33
	2.0	30
	3.0	33
	5.0	46

SIZE	A	B	L	K*D				H	L1	F	L2	L3	M	
				3A	ISO	DIN	DIN11850-2							
DN25	1.0"	46	93	305	50.5*25.4	50.5*25.4	50.5*28	50.5*29	345	95	76	76	95	41*1.5
DN32	1.25"	46	93	305	/	50.5*31.8	50.5*34	50.5*35	345	95	76	76	95	41*1.5
DN40	1.5"	46	93	305	50.5*38.1	50.5*38.1	50.5*40	50.5*41	345	95	76	76	95	41*1.5
DN50	2"	57	106	325	64*50.8	64*50.8	64*52	64*53	365	109	89	89	110	51*1.5
DN65	2.5"	70	118	400	77.5*63.5	77.5*63.5	91*70	91*70	455	125	102	102	125	63*1.5
DN80	3"	80	127	457	91*76.2	91*76.2	106*85	106*85	510	134	114	114	145	73*1.5
DN100	4"	112	146	575	119*101.6	119*101.6	119*104	119*104	632	160	140	140	165	99*1.75