

I Application

The table blender is used to dissolve solids / powders in recirculated liquids. It has a wide range of applications, for example, preparation of pharmaceutical syrups or dissolution of pectin in glucose for marmelade production. Every model has an option with an in-line mixer for a complete dissolution of possible lumps. The typical applications are reconstitution or stabilization of milk in the production of dairy products, and dissolution of sugar for the production of syrup in the beverage industries.

I Operating principle

The table blender is a compact unit, it consists of a centrifugal pump with a venturi system at the suction side and a hopper with a butterfly valve at the upper part to add solids / powders to the pumped liquid. In this blender, the suction and venturi system are set horizontally. If necessary, an in-line mixer can be installed after the centrifugal pump to reduce the size of possible lumps.

The venturi system and the suction of the pump create depression at the base of the hopper. When the valve of the hopper opens, the solids are drawn from the hopper and are totally dissolved when they pass through the casing of the pump.

To achieve the best possible dissolution, it is recommended to recirculate the product (batch production) till all the solid / powder product is suctioned and then, when the solid product is completely incorporated into the liquid, continue recirculating the product for a while. In some cases, the blender can be used in-line depending on the solid product to add and the required level of dissolution.

I Design and features

Very simple and versatile equipment for a fast and homogeneous mixing of a wide range of solid products without any contact with atmosphere.

Hygienic design.

ISO 2852 Clamp connections for easy assembly/disassembly.

Cleaning and disinfection without disassembling the unit.

Complete mixing with recirculation.

Manually actuated butterfly valve for hopper.

Optional in-line mixer for total dissolution of possible lumps in the end product.

Hopper welded to the table with a totally smooth easy-to-clean surface.

St.St. control panel with Stop/Start button and motor protection.

Skid with wheels: 2 rotating + 2 fixed with brakes.

Clamp drain port for total drainage of the skid.



I Technical specifications

Materials:

Parts in contact with the product	AISI 316L (1.4404)
Other steel parts	AISI 304 (1.4301)
Gaskets in contact with the product	EPDM

Mechanical seal:

Rotary part	Silicon carbide (SiC)
Stationary part	Silicon carbide (SiC)
Gaskets	EPDM

Surface finish:

Internal and hopper	Bright polish $Ra \leq 0,8 \mu m$
External, structure and upper base	Matt

Type	Centrifugal pump		In-line mixer		Flow (m ³ /h)	Solids intake* (kg/h)				Hopper (L)
	Model	Power (kW)	Modelo	Power (kW)		Sugar up to 25°brix	Sugar up to 50°brix	Milk powder 20%	Thickener up to 400 cP	
MM-1	HCP	3	-	-	25	1650	1350	950	300	45
MM-1M	50-150		ME-4105	4						
MM-2	HCP	7,5	-	-	40	3700	2400	3300	650	45
MM-2M	50-190		ME-4110	7,5						
MM-3	HCP	18,5	-	-	95	12800	8900	9200	600	75
MM-3M	80-205		ME-4125	18,5						

* Results obtained with water at approximately 20 °C.
The recommended working temperature is below 65 °C.

I Motor

Triphasic induction motor with B5 flange and B3 legs, in compliance with the IEC standards,
2 poles = 3000/3600 rpm, efficiency class according to EC regulation, IP 55 protection and F-class insulation.

3 phases, 50 Hz, 230V Δ / 400 V Y, ≤ 4 kW
3 phases, 50 Hz, 400V Δ / 690 V Y, $\geq 5,5$ kW

I Options

Double mechanical seal.

Solenoid valve for the seal cooling system.

Gaskets: FPM or PTFE.

Connections: DIN, SMS.

Vibrator for hopper.

Frequency converter for the centrifugal pump.

Pneumatically actuated valve + lower level sensor for solids.

Hygienic upper level sensor for solids.

Control panel for the vibrator, level sensors, frequency converter and automated valve.

Grid for hopper.



I Dimensions: table blender MM-1 / MM-2 / MM-3

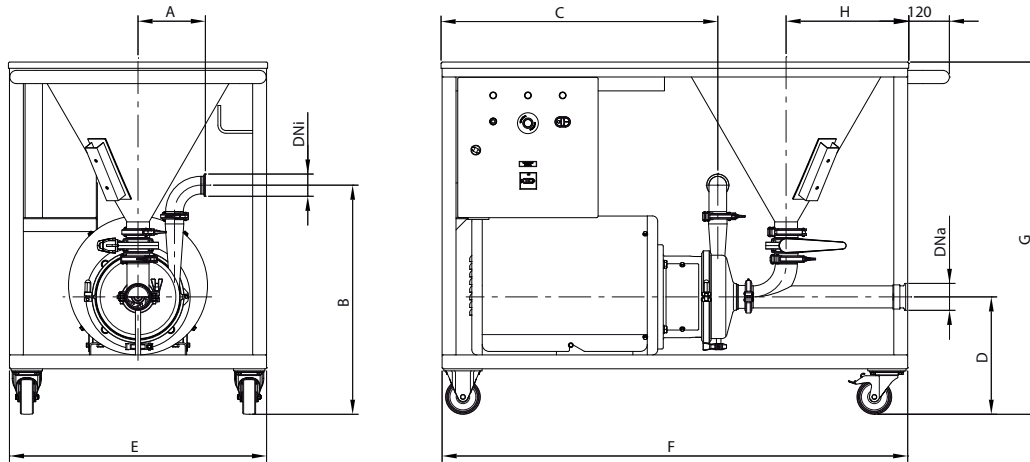

	DNa*	DNi*	A	B	C	D	E	F	G	H	kg
MM-1	2 ½"	2"	161	603	649	320	710	1190	1000	353	130
MM-2	2 ½"	2"	194	660	797	337	740	1340	1014		185
MM-3	4"	3"	240	849	1056	470	850	1770	1268	448	355

*Clamp connections

I Dimensions: table blender MM-1M / MM-2M / MM-3M

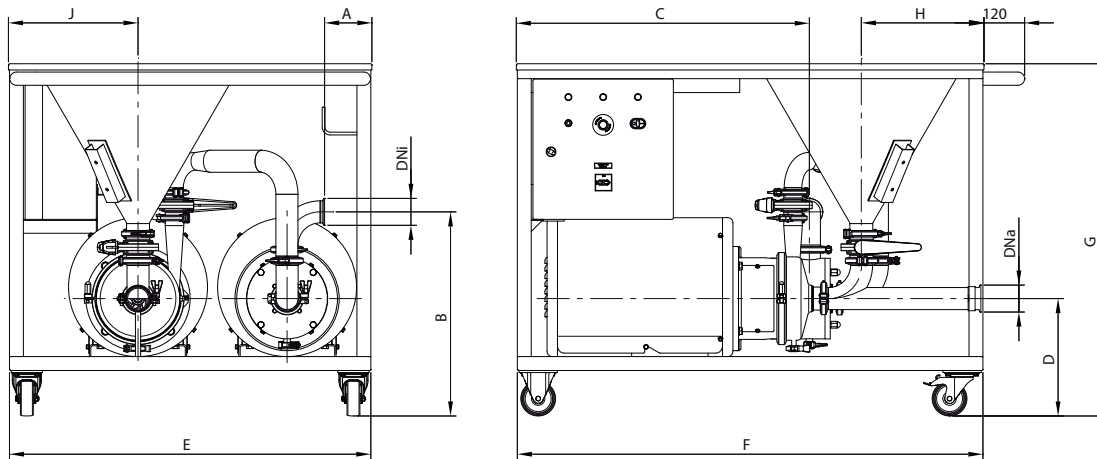

	DNa*	DNi*	A	B	C	D	E	F	G	H	J	kg
MM-1M	2 ½"	2"	134	564	702	320	970	1190	1000	353	358	220
MM-2M	2 ½"	2 ½"	136	588	844	337	1040	1340	1014		373	305
MM-3M	4"	3"	181	773	1090	470	1280	1770	1268	448	428	650

*Clamp connections



FT.MM.2.EN-0718