

I Application

The blenders are used to mix solids in liquids.

In the food-processing industry, they provide a perfect solution for reconstituting powdered milk, making syrups, preparing brines, etc.

They can also be used for preparing solid-liquid mixtures in the pharmaceutical, cosmetics and chemical industries.

I Operating principle

The blender basically consists of a casing and a centrifugal pump impeller which are mounted vertically. The suction side has a double-wall pipe that keeps the inlet of solids separate from that of liquids, thus avoiding the formation of lumps before the material enters the casing.

The liquid enters the mixing chamber at a high speed, thereby creating a vacuum at the center of the impeller, which causes the suction of the solids. The introduction of solids can be regulated by means of a valve situated at the bottom of the hopper.

I Design and features

Simple and versatile assembly for quick and homogeneous mixing of a great variety of solids without contact with the air.

Complete mixing with recirculation of the product

In some applications, it can be used in line, without recirculation.

Sanitary design.

Easy assembly and disassembly by Clamp connections.

Cleaning can be carried out without disassembling the unit.

Sanitary internal single mechanical seal.

Standard hopper of 40° for M-226 and 50° for M-440.

I Applications

Preparation of sugar syrup, sorbitol, glucose, lactose and derivatives.

Reconstitution of powdered milk.

Dissolution of cocoa and/or sugar in milk.

Reconstitution of powdered whey.

Preparation of flour and starch slurries.

Preparation of brines.

Pre-mixtures of yogurt and other milk-based desserts.

Dissolution of bentonites for wine filtering.

Dissolution of casein and caseinates in the cheese-making industry.

Preparation of pesticides and fertilizers.



Haleson

I Technical specifications**Materials:**

Parts in contact with the product	AISI 316L
Gaskets	EPDM

Mechanical seal:

Rotary part	Carbon (C)
Stationary part	Stainless steel (St.St.)
Gaskets	EPDM

Surface finish:

Internal	Bright polish $Ra \leq 0,8 \mu m$
External	Matt

Blender	M-226	M-440
Maximum liquid flow	33.000 l/h	65.000 l/h
Maximum solids suction*	3.000 kg/h	9.000 kg/h
Motor	4 kW - 3.000 rpm	11 kW - 3.000 rpm
Suction connections	CLAMP 1½"	CLAMP 3"
Discharge connections	CLAMP 2"	CLAMP 3"
Hopper	43 L	60 L
Weight	80 kg	240 kg

* The quantity of the suctioned product depends on its properties and the features of the installation.
Please, contact INOXPA technical department to select auxiliary pumps.

It is important to keep low pressure at the suction and at the discharge sides of the blender and avoid cavitation. Thus, a feeding pump must be provided only for the applications that really require it (considerable pressure drops at the suction side, high viscosity products, etc.), please, keep in mind that the suction capacity will decrease.

When discharge pressure is high, a centrifugal pump needs to be fitted to the discharge side of the blender.

For viscosities above 500 cP, the feeding pump and the discharge pump must be positive displacement pumps.

I Options

Double flushed seal.

Double pressurised seal.

Connections: DIN, SMS.

Vibrator for the hopper.

Pneumatically actuated valve + hygienic solids lower level sensor.

Hygienic solids upper level sensor.

Control panel for vibrator, solids level sensors, frequency converter, automated valve.

Grid for the hopper.

60° hopper.

Drainage.

ATEX version available.

Internal surface finish: $Ra \leq 0.5 \mu m$.



I Hopper vibrator

Considering the problems with the complete discharge of solids such as very fine powders, we offer the option of installing a vibrator in the hopper.

Pneumatic vibrator: The vibration is produced by means of a roller rolling on steel grooves. The frequency of vibration is changed by regulating the entry of air into the vibrator.

The vibration keeps the flow of solids until the hopper is completely empty, thus no solids are left on the walls of the hopper.

If strong vibration is required, the mixer will be adapted to operate under the relevant conditions. This adaptation is made by means of an anti-vibration support for the hopper and an elastic coupling.

I Solids detection sensor

Due to the high degree of automation of the processes, it is important that all the parameters are controlled. We offer the option of adding one or two solids detection sensors to the hopper.

These sensors provide a signal to indicate lower and/or upper solids level in the hopper. The signal of the lower level sensor can be used to control the valve in the lower part of the hopper in order to avoid the entry of air into the mixing chamber. The upper level sensor can be used to control the solids feeding unit.

This type of sensor uses a high frequency signal in the tip area to detect solids. The detection sensibility can be adjusted and it can be used for all types of products, solids, granules, liquids, pastes, oils.

Features:

- reduced dimensions in the contact area
- G ½ thread with hygienic liner
- parts in contact with the product in PEEK

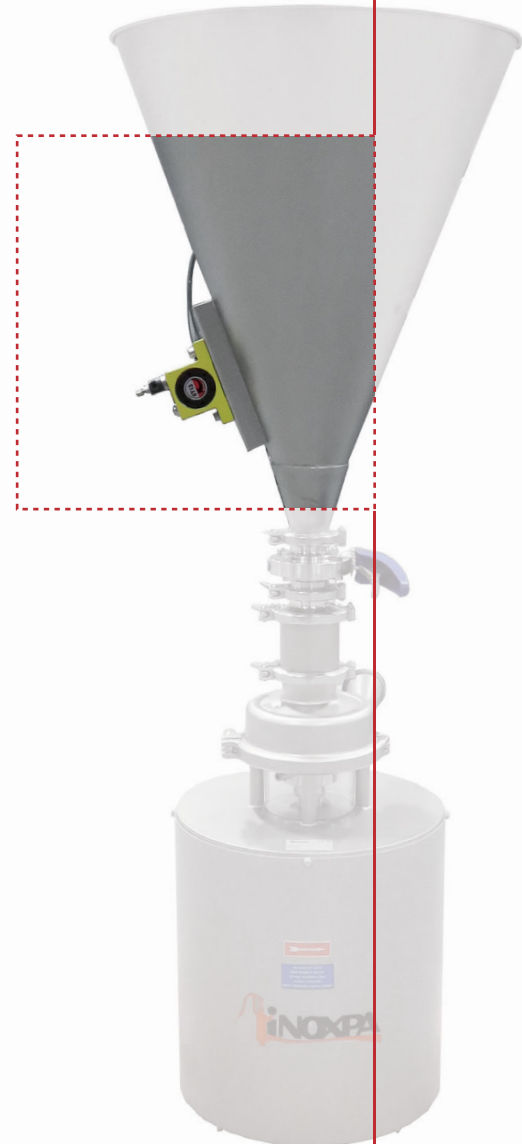

I Dimensions blender M-226

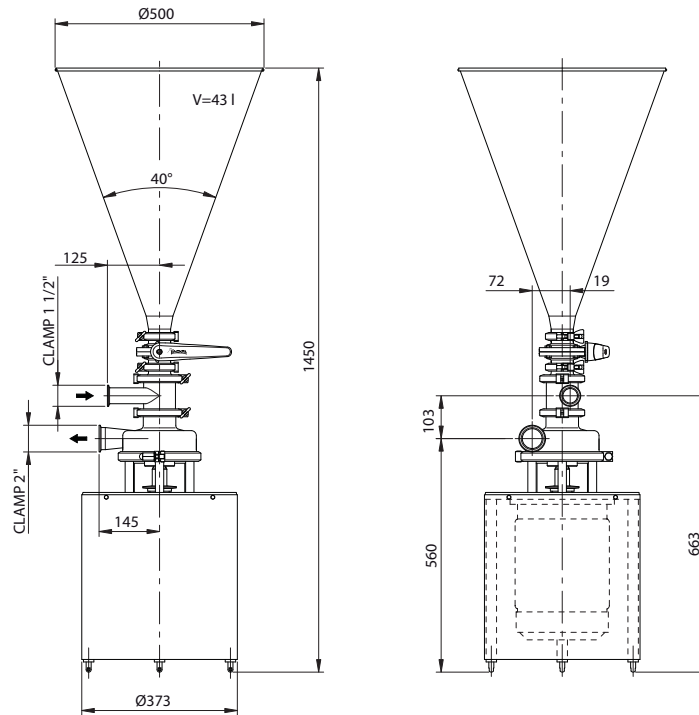

I Dimensions blender M-440

