

I Application

The PBC series agitators are vertical direct motor-driven agitators with clamp. They are widely used in processes of mixing, dissolution, dispersion, and maintenance whenever powerful and high-speed agitation is required in the food processing, cosmetics, pharmaceutical or chemical industries.

The agitators can be fitted to small tanks of up to 1500 liters for work with low-viscosity products.

I Operating principle

These agitators are fixed to the wall of the tank by means of a clamp, thanks to the joint, they can be inclined to the required position.

The rotation of the propeller makes the fluid flow to the bottom of the tank and then up to the surface of the product along the tank wall opposite to the wall the agitator is fitted to. This effect is promoted if the bottom of the tank is curved.

I Design and features

Agitator with clamp.

Retainer.

Bearing support.

Propeller attached to shaft and shaft attached to half-shaft by Allen setbolts.

IEC B14 motors, 1500 rpm, IP 55, F-class insulation.

Maximum power 0,75 kW.

Lineflux propeller (Type 18).

I Materials

Parts in contact with the product	AISI 316L
Retainer	NBR
Bearing support	Aluminum
Surface finish	$Ra \leq 0,8 \mu m$

I Options

Retainer in FPM.

Welded propeller with $Ra \leq 0,5 \mu m$ surface finish.

Motors: 950 rpm or 750 rpm.

Motors with other protections.

Motor shroud.

Pneumatic drive.



I Technical specifications and dimensions

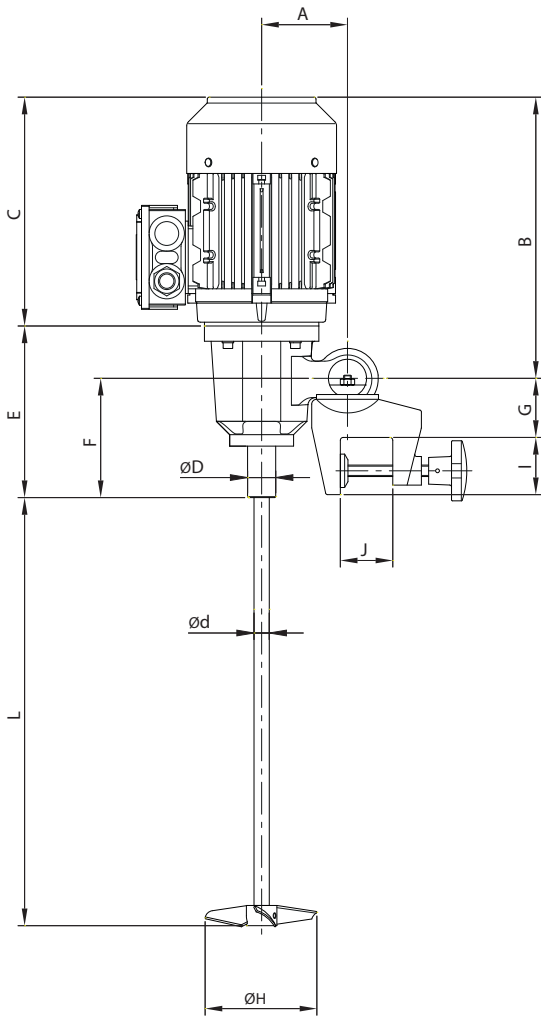

Type		PBC 1.18-4007-1-100	PBC 1.18-4007-1-130	PBC 1.18-4007-1-150	PBC 1.18-6005-1-130	PBC 1.18-6005-1-150	
Motor power	[kW]	0,75			0,55		
Speed	[rpm]	1420			900		
Volume [H ₂ O]	[m ³]	0,1 - 0,6	0,2 - 0,8	0,4 - 1,5	0,1 - 0,7	0,15 - 1	
Dimensions	A	90					
	B	305					
	C	250					
	ØD	30					
	E	180					
	F	124					
	G	62					
	I	60					
J max.	45						
Agitator shaft	Ød	16					
	L max.	1250					
Lineflux propeller	ØH	[mm]	100	130	150	130	150
Weight	[kg]	18			17		



Haleson

FTPBC.3.EN-0120