

I Application

The NBI series agitators are medium speed vertical agitators with geared motor. These agitators can be used in processes of mixing, dissolution, dispersion, and maintenance whenever a medium or mild agitation of medium or low viscosity products is required in the food processing, cosmetics, pharmaceutical or chemical industries.

I Operating principle

The agitators are normally installed inside the tank either centrally with current deflectors, or offset to prevent the rotation of the stirred product.

The rotation of the propeller makes the fluid flow to the bottom and then up to the surface of the product along the walls of the tank. The effect is promoted if the bottom of the tank is curved.

I Design and features

Vertical agitator.

Sealing: V-ring.

Propeller attached to shaft and the shaft attached to the geared motor by Allen studbolts.

Helical gear unit with reinforced bearings and food-grade oil.

Motors: IP 55, F-class insulation.

Maximum power 1,1 kW.

Marine propeller (Type 10).

I Materials

Parts in contact with the product

Stainless steel AISI 316L

V-ring

NBR

Surface finish

$Ra \leq 0,8 \mu m$

I Options

V-ring: FPM.

Welded propeller with $Ra \leq 0,5 \mu m$ surface finish.

Shaft and propeller lined with plastic material for use with corrosive products.

Drive shroud.

Motors with other protections.



I Technical specifications and dimensions

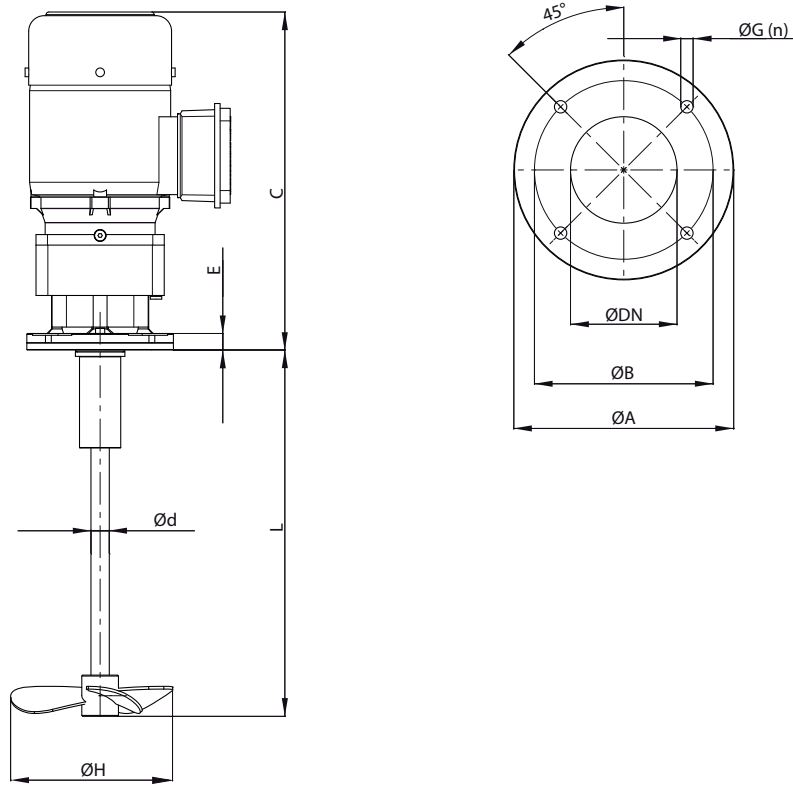

Agitator	Flow [m ³ /h]	Tank [L]	Motor power [kW]	Speed [rpm]	Dimensions				Agitator shaft		Type	Weight [kg]		
					C	E	Flange		Ø d	L max	Ø H		10	
							Ø A	Ø B					Ø DN	Ø G(n)
NBI 1.10-20005-200	58	up to 250	0,55	200	367	18	160	130	77,5	9 (4)	20	1400	200	20
NBI 1.10-20005-250	113	500											250	21
NBI 1.10-20005-300	194	1000											300	21
NBI 1.10-20011-350	309	2000	1,1	476									350	35
NBI 1.10-20011-400	461	2500											400	



FT.NBI2.EN-1217