



INSTALLATION, SERVICE AND MAINTENANCE INSTRUCTIONS

IN-LINE MIXER 4100 SERIES



03.400.32.0001

INOXPA, S.A.
c/Telers, 54 Aptdo. 174
E-17820 Banyoles
Girona (Spain)
Tel. : (34) 972 - 57 52 00
Fax. : (34) 972 - 57 55 02
Email: inoxpa@inoxpa.com
www.inoxpa.com



Haleson

03.400.30.00EN
(B) 2015/01



EC Declaration of Conformity

The manufacturer: **INOXPA, S.A.**
c/ Telers, 57
17820 Banyoles (Girona), Spain

herewith declares that the machine:

ME-4100 Mixer

with the serial number: _____

conforms to the relevant provisions of the following directives:

Machinery Directive 2006/42/EC (RD 1644/2008)
Low voltage Directive 2006/95/EC
Electromagnetic Compatibility Directive 2004/108/EC

Applicable harmonised Standards:

UNE-EN ISO 12100:2012

Identification of the person empowered to draw up the Declaration on behalf of the manufacturer, and qualified to compile the technical file established by the Community:

Banyoles, 8 January 2014

A handwritten signature in black ink, appearing to read 'David Reyer Brunet', is written over a light grey signature line.

David Reyer Brunet
Technical Office Manager

1. Safety

1.1. INSTRUCTIONS MANUAL

This instruction manual contains information on the reception, installation, operation, fitting, stripping and maintenance for the In-line Mixer.

The information given herein is based on the most up-to-date data available.

INOXPA reserves the right to modify this instructions manual without having to give prior notice.

1.2. START-UP INSTRUCTIONS

This instruction manual contains vital and useful information for properly operating the mixer and for keeping it in good running condition.

Not only should the safety instructions set forth in this chapter be carefully read before putting the mixer into operation, but those concerned must also familiarize themselves with the operating features of the mixer and strictly adhere to the instructions given herein. It is extremely important that these instructions be kept in a set place near the installation.

1.3. SAFETY

1.3.1. Warning signs



Danger for people in general



Danger of injury caused by rotating parts of the equipment



Danger! Electricity



Danger! Caustic or corrosive agents



Danger! Suspended loads



Danger to the proper operating of the machine



Obligation to ensure safety at work



Use safety goggles obligatory

1.4. GENERAL SAFETY INSTRUCTIONS



Please read the instruction manual carefully before installing and commissioning the mixer. Should you have any doubts or queries, contact INOXPA.

This equipment is suitable for his use in food process.

1.4.1. During the installation



You must always bear in mind the *Technical Specifications* set forth in Chapter 8.

Do not put the mixer into operation before connecting it to the pipes.

Do not put the mixer into operation if the cover of the mixer has not been fitted and the impeller fixed in the mixer.

Check that the motor specifications are correct, especially if there is a special risk of explosion due to the work conditions.



During the installation procedure, all the electrical work must be carried out by duly authorized personnel.

1.4.2. During operation



You must always bear in mind the *Technical Specifications* set forth in Chapter 8. The limit values that have been set must NEVER be exceeded.

NEVER touch the mixer or pipes whenever the mixer is being used to decant hot liquids or during the cleaning procedure.



The mixer has moving parts. Do not put your fingers into the mixer when it is operating.



NEVER work with the suction and the delivery valves shut off.

NEVER directly sprinkle the electric motor with water. Standard motor protection is IP-55: dust and water sprinkling protection.

1.4.3. During maintenance



You must always bear in mind the *Technical Specifications* set forth in Chapter 8.

NEVER strip the mixer down until the pipes have been drained. Remember that there will always be some liquid left in the mixer casing (if it has not been fitted with a drain). Always remember that the liquid that has been mixed may be dangerous or subject to high temperatures. For situations of this type, please consult the prevailing regulations in the country in question.

Do not leave loose parts on the floor.



ALWAYS turn the power supply to the mixer off before embarking on maintenance work. Take out the fuses and disconnect the wires.

All electrical work must be carried out by duly authorized personnel.

1.4.4. In accordance with the instructions

Any failure to comply with the instructions could lead to a hazard for the operators, the atmospheric conditions of the room, and the machine, and it could lead to a loss to any right to make a claim for damages.

Such non-compliance could bring with it the following risks:

- Important operating failures of the machine / plant.
- Failure to comply with specific maintenance and repair procedures.
- Potential electrical, mechanical and chemical hazards.
- Atmospheric conditions in the room could be hazardous due to the release of chemical substances.

1.4.5. Warranty

We wish to point out that any warranty issued will be null and void and that we are entitled to an indemnity for any civil liability claim for products which might be filed by third parties if:

- Operation and maintenance work has not been done following the corresponding instructions; the repairs have not been made by our personnel or have been made without our written authorization;
- Modifications are made to our material without prior written authorization;
- The parts or lubricants used are not original INOXPA parts/lubricants;
- The material has been improperly used due to error or negligence or have not been used according to the indications and the intended purpose.
- The parts of the mixer have been damaged as a result of having been exposed to strong pressure as there was no safety valve.

The General Delivery Terms which you have already received are also applicable.



No modification can be made to the machine without the prior consent of the manufacturer. For your safety, use spare parts and original accessories.
The use of other parts exempts the manufacturer from any and all responsibility.

Any change in operating conditions can only be done with the prior written consent of INOXPA.

In the event of doubt or should you require a fuller explanation on particular data (adjustment, assembly, disassembly...), please do not hesitate to contact us.

2. Index

1. Safety	
1.1. Instructions manual.....	3
1.2. Start-up instructions.....	3
1.3. Safety.....	3
1.4. General safety instructions.....	3
2. Index	
3. General Information	
3.1. Description.....	7
3.2. Operating principle.....	7
3.3. Application.....	7
3.4. Hygiene.....	7
3.5. Construction materials.....	7
4. Installation	
4.1. Mixer reception.....	8
4.2. Transport and storage.....	8
4.3. Location.....	9
4.4. Pipes.....	9
4.5. Pressurised tank.....	9
4.6. Electric installation.....	10
5. Start-up	
5.1. Start-up.....	11
6. Operating problems	
7. Maintenance	
7.1. General maintenance.....	13
7.2. Storage.....	13
7.3. Cleaning.....	13
7.4. Disassembly / assembly of the ME-4101/ 4103/ 4105/ 4110 mixer.....	14
7.5. Disassembly/ assembly of the ME-4125/4130 mixer.....	19
8. Technical Specifications	
8.1. Technical specifications.....	24
8.2. Weights.....	24
8.3. ME-4100 Mixer dimensions.....	25
8.4. ME-4101/4103/4105/4110 Mixer.....	26
8.5. ME-4101/4103/4105/4110 Mixer.....	27
8.6. Parts list ME-4101/4103/4105/4110 Mixer.....	28
8.7. ME-4125/4130 Mixer.....	29
8.8. ME-4125/4130 Mixer.....	30

8.9. Parts list ME-4125/4130 Mixer	31
8.10. ME-4101/4103/4105/4110 Mixer cooled mechanical seal	32
8.11. ME-4125/4130 Mixer cooled mechanical seal	33
8.12. ME-4101/4103/4105/4110 Mixer double mechanical seal.....	34
8.13. ME-4125/4130 Mixer double mechanical seal.....	35

3. General Information

3.1. DESCRIPTION

ME-4100 In-line Mixers are compactly built, axially exhausting and radially impelling, while the connections are of the sanitary type. The mixer casing, the rotor and the stator are all mechanised. All of the parts that come into contact with the product are made of stainless steel.

The ME-4100 range is designed for continuous operation. Its most significant construction characteristics are as follows:

- Monoblock execution.
- Rotor-stator design.
- Sanitary mechanical seal.
- B35 Motor.

3.2. OPERATING PRINCIPLE

- Head suction is produced by the intake mouth.
- The impeller pushes the product towards the stator, where it is sheared.
- The product is radially discharged through the stator holes at great speed.
- Strong circulation is provoked under the surface.

It turns in a clockwise direction, when the Mixer is viewed from the rear part of the motor.

3.3. APPLICATION

In-line mixers are ideal for processes that require particle reduction, dissolution, dispersion and emulsion. Given its sanitary design, these Mixers are ideal for such demanding industries as the cosmetic, food and pharmaceutical sectors. They can also be used in other ones such as the adhesive, chemical, paints, and plastics industries.

3.4. HYGIENE

Special attention has been made in the design of the mixer to the hygiene factor and cleaning possibilities. The number of slots and idle spaces have been reduced to an absolute minimum.

The mixer can be cleaned simply and thoroughly in either of the following ways:

- Without stripping down, for example: by means of steam or water, the so-called Cleaning In Place (CIP) method.
- Simply by means of stripping the mixer.

Refer to Section 7.2 "Cleaning" with respect to how to properly clean the mixer, and the cleaning products that must be used.

3.5. CONSTRUCTION MATERIALS

All of the parts of the mixer that come into contact with the product are made of stainless steel, or are made of insipid and odourless materials. This means that the mixer is corrosion proof, which means that the contamination of the liquid being mixed is avoided.



During manufacturing, the materials of the parts that come into contact with the product must be checked in order to make sure that they are suitable to house the pumping of food products.

Table 3.1: Parts that come into contact with the liquid.

Part	Material
Mixer casing	AISI 316L (1.4404)
Rotor	AISI 316L (1.4404)
Stator	AISI 316L (1.4404)
Mixer cover	AISI 316L (1.4404)
Motor-shaft	AISI 316L (1.4404)
Impeller nut	AISI 316L (1.4404)

Table 3.2: Parts that may come into contact with the liquid.

Part	Material
Lantern	AISI 304 (1.4308)

4. Installation

4.1. MIXER RECEPTION



INOXPA is not responsible for any deterioration of the material as a result of its transportation or unpacking. Visually check that the packing has not suffered any damage.

The mixer will be accompanied by the following documentation:

- Dispatch notes.
 - Mixer Instruction and Service Manual.
 - Motor Instruction and Service Manual (*).
- (*) If the mixer has been supplied with a motor from INOXPA.

Unpack the mixer and check the following:

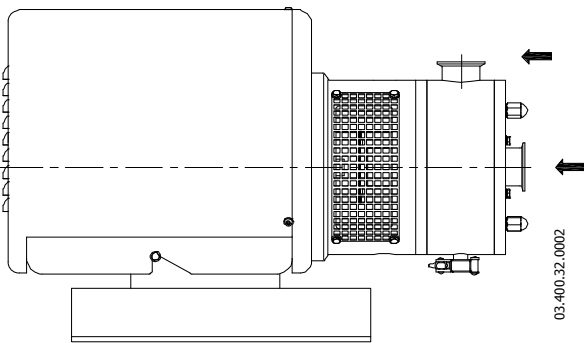

- The mixer drainage connection and mixer suction and delivery connections, removing the remains of any packing material.
- Check that the mixer and the motor have not suffered any damage.
- Should the mixer not be in proper condition and/or does not have all the parts, the haulier must draw up a report as soon as possible with regard to the same.

4.1.1. Mixer identification and marking

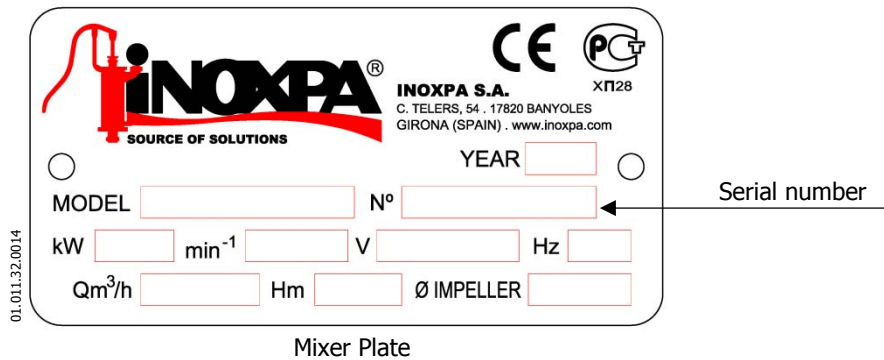

4.2. TRANSPORT AND STORAGE



ME-4100 series Mixers are quite often too heavy to be put into their storage space manually.

Lift the Mixer as is shown below:

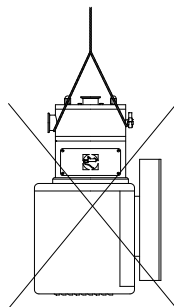
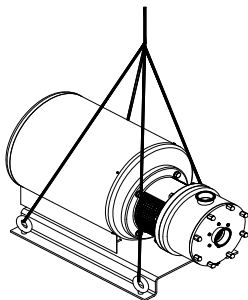

Never lift the whole mixer assembly by the mixer casing

4.3. LOCATION

Position the mixer as near as possible to the suction tank, and whenever possible below the level of the liquid. Place the mixer in such a way that there is enough space around it to provide access both to the same and to the motor. (See Chapter 8. *Technical specifications* to consult dimensions and weights).

Place the mixer on a level and flat surface.

The basement must be rigid, horizontal and against any vibration.



Install the mixer in such a way that it can be properly ventilated. If the mixer is to be installed outside, it must be done so under cover. Its positioning must enable easy access for any inspection and maintenance operations that may need to be carried out.

4.4. PIPES

- In general, suction and delivery pipes should be fitted in straight stretches, with the minimum amount of elbows and accessories, in order to reduce, as far as possible, any pressure loss that might be produced by friction.
- Make sure that the mixer mouths are well aligned with respect to the piping, and that they are similar in diameter to that of the pipe connections.
- Position the mixer as near as possible to the suction tank, and whenever possible below the level of the liquid, or even lower with respect to the tank in order for the static suction head to be at its maximum.
- Place brackets for the piping as near as possible to the suction and delivery mouths of the mixer.

4.4.1. Shut-off valves

The mixer can be isolated for the purpose of carrying out maintenance work. To this end, shut-off valves should be fitted at the mixer's suction and delivery connections.

These valves must ALWAYS be open whenever the mixer is operating.

4.5. PRESSURISED TANK

For models with double mechanical seal will be necessary the installation of a pressure tank.



Install ALWAYS the pressure tank between 1 and 2 meters above the mechanical seals. See the figure 4.6.1.

Connect ALWAYS the refrigeration liquid input connection with the bottom chamber seal connection. So, the refrigeration liquid outlet will be carried out by the top chamber connection. See the figure 4.6.1.

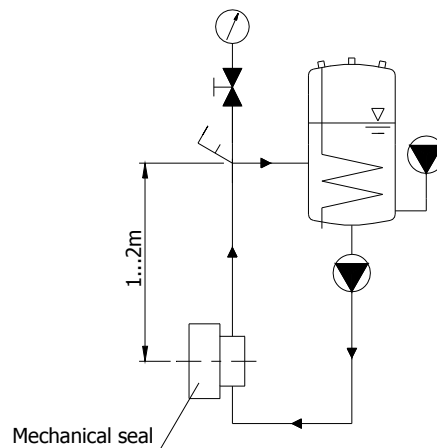

Figure 4.6.1: Pressure tank connection lay out.

To obtain further information about the pressure tank (installation, operation, maintenance, ...), consult the instruction manual supplied by the manufacturer.



NEVER put the Mixer into operation if the cover has not been fitted and the rotor secured.

4.6. ELECTRIC INSTALLATION



Leave the connecting of the electrical motors to qualified personnel.

Take the necessary measures to prevent any breakdowns in the connections and wires.



The electrical equipment, the terminals and the components of the control systems may still carry an electric charge even when disconnected. Contact with them may put the safety of operators at risk, or cause irreparable damage to the material.

Before maneuvering the mixer, make sure that the electric box is switched off.

- Connect the motor in accordance with the instructions supplied by the manufacturer of the same.
- Check the direction of the rotation (see the signaling label on the mixer).



NEVER put the Mixer into operation if the cover has not been fitted and the rotor secured.

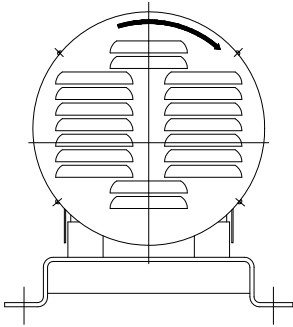

Put the mixer motor into operation momentarily. Make sure, by looking at the mixer from the rear, that the motor's ventilator is rotating in a clockwise direction.



Check **ALWAYS** the direction of the motor's rotation with liquid inside the mixer.

For the models with sealing chamber, make sure always that it is filed of liquid before checking the rotating direction.

5. Start-up



Before putting the mixer into operation read carefully the instructions on installation given in Chapter 4. *Installation*

5.1. START-UP



Read Chapter 8. *Technical Specifications* carefully. INOXPA will not assume responsibility for any improper or incorrect use of the equipment.



NEVER touch the mixer or the pipes when hot fluid is being mixed.

5.1.1. Checks to be carried out before putting the Mixer into operation

- Completely open the pipes' suction and delivery shut-off valves.
- In the event that the liquid does not flow towards the Mixer, use the feed mixer. The In-line Mixer can overcome a limited delivery pressure. This feed mixer can be used to overcome a possible high delivery pressure.
- For high viscosity products, a positive displacement feed mixer should be used.



The Mixer must **NEVER** rotate without liquid.

- Check that the motor turning direction is correct.

5.1.2. Checks to be carried out on putting the Mixer into operation

- Check to make sure that the Mixer is not making any strange noises.
- Check to see if the absolute inlet pressure is sufficient, in order to avoid cavitation in the mixer.
- Monitor the delivery pressure.
- Check that there are no leaks in the sealed areas.



A shut-off valve should not be used in the suction pipe to regulate the flow rate. It must be completely open during operation.



Monitor motor consumption in order to avoid a circuit overload.

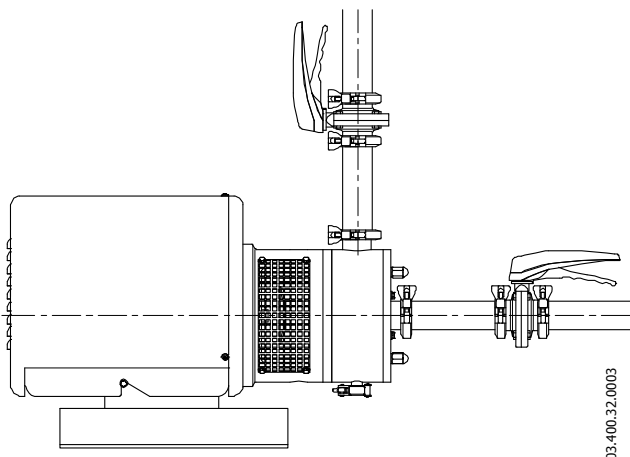

Reduce the flow and the power consumed by the motor:

- Regulating the flow to the mixer delivery.
- Decreasing motor speed.

6. Operating problems

The table given below provides solutions to problems that might arise during mixer operation. With respect to the same, it is assumed that the mixer has been properly installed and has been correctly selected for the application in question. Should there be a need for technical service please contact INOXPA.

Operating incidents	Probable causes
Overloading of motor.	8, 9, 13, 20, 21.
Insufficient flow rate or pressure in mixer.	1, 2, 4, 5, 7, 9, 10, 17, 19.
No pressure on the discharge side.	2, 3, 6, 18.
Irregular discharge flow rate / pressure.	1, 2, 4, 5, 6, 9.
Noise and vibrations.	2, 4, 5, 6, 7, 8, 9, 10, 13, 14, 15, 20, 21.
The mixer gets clogged.	9, 10, 13, 15, 20, 21.
Overheating of the mixer.	8, 9, 10, 13, 15, 20, 21.
Abnormal wear.	4, 5, 10, 15, 20, 21.
Leak in mechanical seal.	11, 12, 16.

Probable causes	Solutions
1 Wrong rotation direction.	Change the direction of the rotation.
2 Insufficient NPSH.	Increase the NPSH available: - Raise the suction tank. - Lower the mixer. - Decrease the steam tension. - Increase the diameter of the suction piping. - Shorten and simplify the suction piping.
3 Non-purged mixer.	Purge or fill.
4 Cavitation.	Increase the suction pressure.(See Number 2 also)
5 The mixer is sucking air.	Check the suction piping and all of its connections.
6 Obstructed suction piping.	Check the suction piping and the filters, if there are any.
7 Delivery pressure is too high.	If necessary, decrease the load losses by increasing the diameter of the piping, for example.
8 Flow is too high.	Decrease the flow: - Reduce the flow by means of a diaphragm. - Partially close off the delivery valve. - Trim the impeller. - Decrease the speed.
9 The viscosity of the liquid is too high.	Decrease the viscosity by heating the liquid, for example.
10 The temperature of the liquid is too high.	Decrease the temperature of the liquid by cooling it.
11 Mechanical seal either damaged or worn.	Replace the seal.
12 Unsuitable O-ring gaskets for the liquid in question.	Fit more suitable O-ring gaskets by consulting the supplier with respect to the same.
13 The impeller is rubbing.	- Lower the temperature. - Lower suction pressure. - Adjust impeller / cover set.
14 Pressure in the pipes.	Connect the pipes to the mixer without pressure.
15 There are foreign bodies in the liquid.	Place a filter at the suction piping.
16 The tension of the mechanical seal spring is too low.	Adjust in accordance with the instructions given herein.
17 The mixer speed is too low.	Increase the speed.
18 The suction shutoff valve is closed.	Check and open.
19 Delivery pressure is too low.	Increase the pressure: - Increase the diameter of the impeller. - Increase mixer speed.
20 Pressure on the pipes.	Connect the pipes to the mixer without pressure and align the coupling.
21 Mixer and/or motor not fixed to the base-plate.	Affix the mixer and/or the motor to the base-plate, check to see if the pipes are connected without pressure and align the coupling.



If the problems persist stop using the mixer immediately. Contact the mixer manufacturer or his representative.

7. Maintenance

7.1. GENERAL MAINTENANCE

This mixer, as with any other machine, needs to be maintained. The instructions contained in this manual deal with the identification and replacement of the spare parts. These instructions have been drawn up by maintenance staff and are destined for those people who are responsible for supplying spare parts.



Read carefully Chapter 8. **Technical Specifications**.

All the parts or materials that are changed must be duly eliminated/recycled in accordance with the prevailing directives in each area.



ALWAYS disconnect the mixer before starting out on any maintenance work.

7.1.1. Check the mechanical seal

Periodically check that there are no leaks in the shaft area. Should there be any leaks in the mechanical seal area, replace the same pursuant to the instructions given in the section entitled Mixer disassembly / assembly.

7.2. STORAGE

Before being stored the mixer must be completely emptied of liquids. Avoid, as far as possible, the exposure of the parts to excessively damp atmospheres.

7.3. CLEANING



The use of aggressive cleaning products such as caustic soda and nitric acid may give rise to skin burns.

Use rubber gloves during the cleaning process.



Always use protective goggles.

If the mixer is installed in a system with a CIP process, it is not necessary to disassemble the mixer.

If the automatic cleaning process is not provided, proceed to disassemble the mixer as indicated in the Disassembly and Assembly section.

Cleaning solutions for CIP processes

Use only clear water (without chlorides) for mixing with the cleaning agents:

a) Alkaline solution: 1% in weight of caustic soda (NaOH) at 70°C (150°F)

1 Kg NaOH + 100 l. water = cleaning solution

or

2.2 l. NaOH at 33% + 100 l. water = cleaning solution

a) Acid solution: 0.5% in weight of nitric acid (HNO₃) at 70°C (150°F)

0.7 liters HNO₃ at 53% + 100 l. water = cleaning solution



Control the concentration of the cleaning solutions to avoid deterioration of the mixer seals.

To remove the remaining cleaning products, **ALWAYS** perform a final rinse with clean water on completion of the cleaning process.

7.4. DISASSEMBLY / ASSEMBLY OF THE ME-4101/ 4103/ 4105/ 4110 MIXER

7.4.1. Mixer casing and stator

Disassembly

Remove the mixer from its location.

Clean and dry the Mixer.

Loosen the nuts (45A), which will enable you to take off the cover (03A), as well as remove the mixer casing (01) and the seal (80).

By loosening the screws (52B) it will be possible to take the stator (22) from the cover and take out the seals (80C and 80D).

Assembly

Position seals (80C and 80D) in their positions on the stator (22).

Fit the stator onto the cover (03A) and secure by means of the corresponding screws (52B).

Position the seals (80) in the covers (03 and 03A) and fit the latter into the mixer casing (01) onto the tie rods (29), after having screwed same to the lantern (04).

Secure the parts with nuts (45A).

Fit the mixer in position.

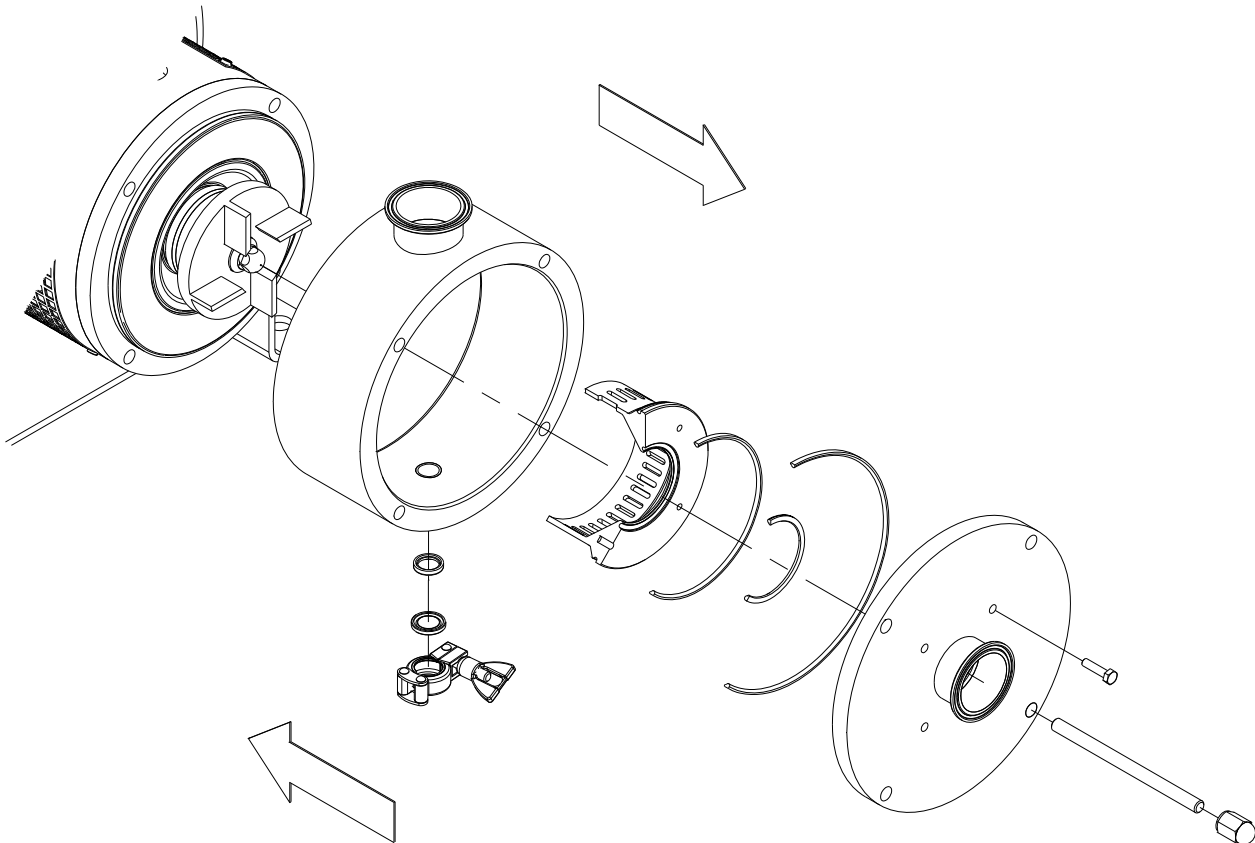

7.4.2. Simple mechanical seal

⇒ Disassembly

Remove the nut (45) and take it out along with the seal (80A), which will enable it to take out the impeller (21) and the mechanical seal (08).

Take out the protectors (47) removing the screws (50).

Take out the screws (52A) and washers (53B) then remove the cover (03) along with the box (09).

Take out the screws (52D) and the washers (53A), which will enable the removal of the box (09) from the cover (03) and the seal (80 and 80E).

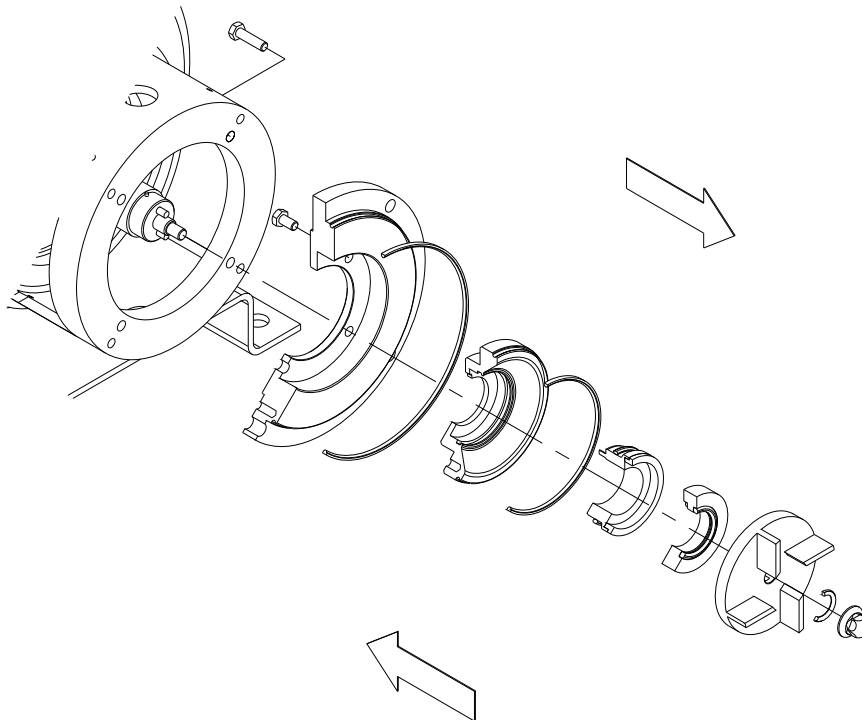

!IMPORTANT! When assembling the new seal, be careful and mount the parts and the O-ring with soapy water in order to allow an easy glide of the parts, either the stationary part and the rotary part on the shaft.

⇐ Assembly

Fit the box (09) onto the cover (03) and the seals (80 and 80E), securing both parts by means of the screws (52D).

Secure the cover-box assembly in the lantern (04) by means of the corresponding screws (52A).

Fit the fixed part of the seal (08) in the box lantern (09), taking the spindle into account.

Make sure that the assembly or fitting measurement is the one that is given below:

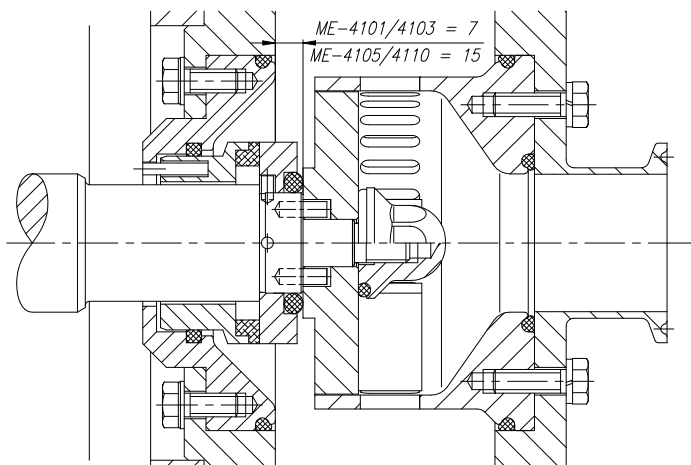

Slide the rotating part of the mechanical seal (08) along the shaft (05) facing the slot to the spindle until coming to the end of same.

Then position the impeller (21) on the shaft. Position the seal (80A) and strongly tighten the nut (45) by means of a spanner.

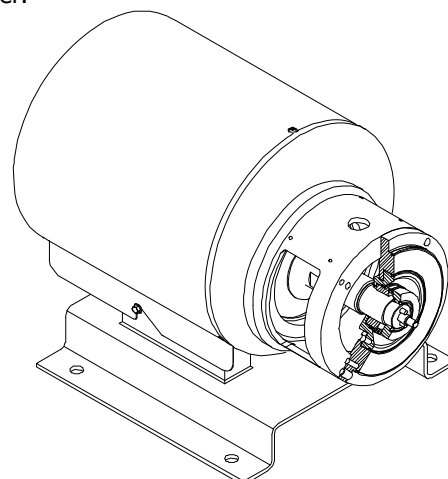

03.400.32.0004

7.4.3. Cooled mechanical seal.

⇒ Disassembly

Remove the nut (45) and take it out along with the seal (80A), which will enable the impeller (21) and the mechanical seal (08) to be taken out.

Loosen and remove the seal (92).

Take out the screws (52A) and washers (53B) then remove the cover (03) along with the box (09), seal cover (10), seal ring (10) and the stationary seal seat (08C).

Remove the stationary seal seat (08C), to do so take out nuts (54) and the seal ring (30).

Take out the seal cover (10) and the seal (80F). and finally take out the box (09) and the studs (55A).

Remove the rotating part of the seal (08B) by means of loosening the setscrews with which it is equipped.

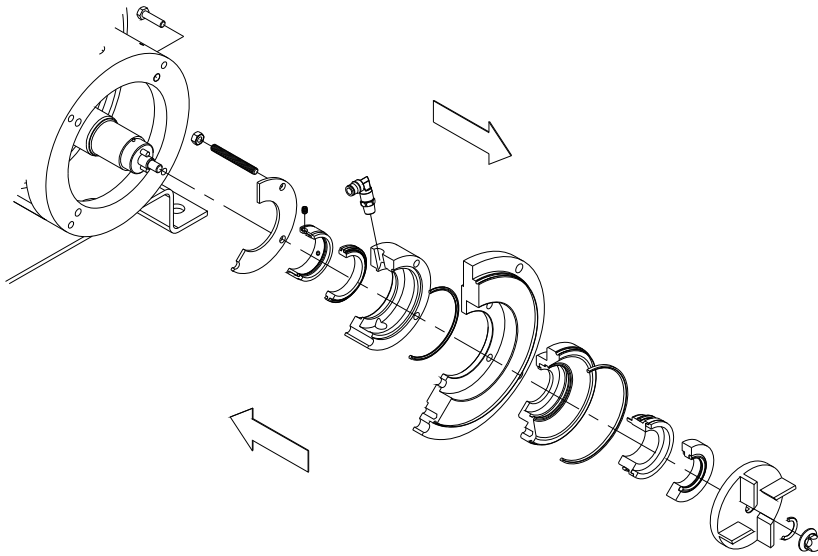

!IMPORTANT! When assembling the new seal, be careful and mount the parts and the O-ring with soapy water in order to allow an easy glide of the parts, either the stationary part and the rotary part on the shaft.

⇐ Assembly

Slide the rotating part of the external mechanical seal (08B) on the shaft until it reaches its end on same, and secure it by means of its Allen setscrews and the studs (55A).

Put the seal (80E) into the box (09) and fit it into the cover (03).

Position the stationary seal seat (08C) in the seal cover (10).

Position the seal (80F) in the box stud (09).

Slide the seal seat assembly and the box until it goes as far as it can into the cover (03).

Fit the seal ring (30) and secure the whole group with the corresponding nuts (54). Before tightening the nuts, position the cooling inlet and outlet holes.

Put the box-cover-seal onto the shaft (05) until it reaches up to the lantern (04) and secure tightly by means of screws (52A) and the washers (53B).

Fit the internal mechanical seal (08) following the steps given in 7.3.2 (Assembly. Simple seal)

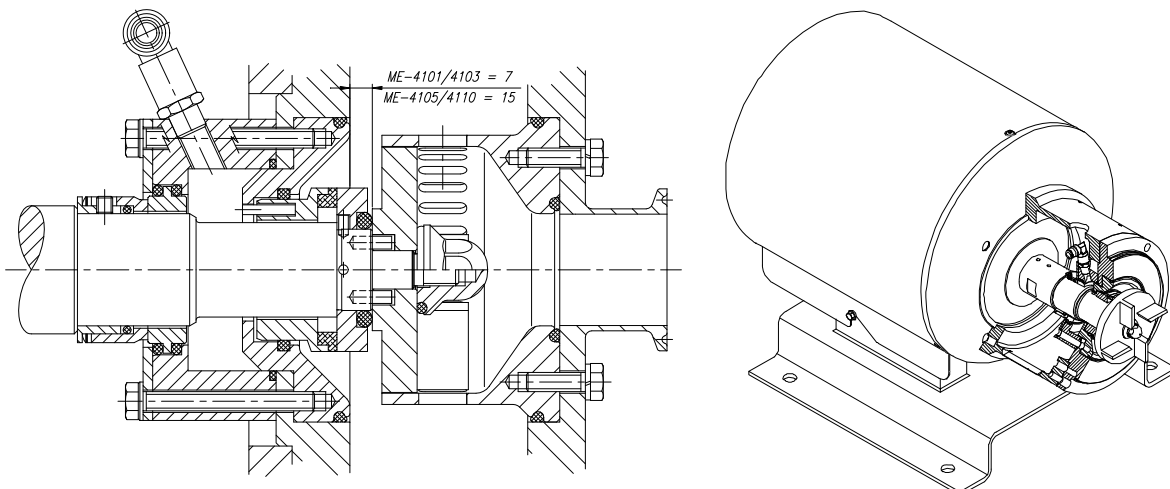

03-400.32.0005

7.4.4. Double mechanical seal

⇒ Disassembly

Remove the nut (45) and take it out along with the seal (80A), which will enable the removal of the impeller (21) and the seal (80G).

Remove and take out the seals (92). Remove the nuts (54), screws (52D) and washers (53A), which will enable the taking out of the cover (03) along with the box (10C) and the stationary part of the internal mechanical seal.

Take out the part (10A) and the seal (80F). Loosen the Allen screws that secure the rotary part of the seal (08D), which will enable the removal of this part.

Take out the cover (10B) along with the stationary part of the seal.

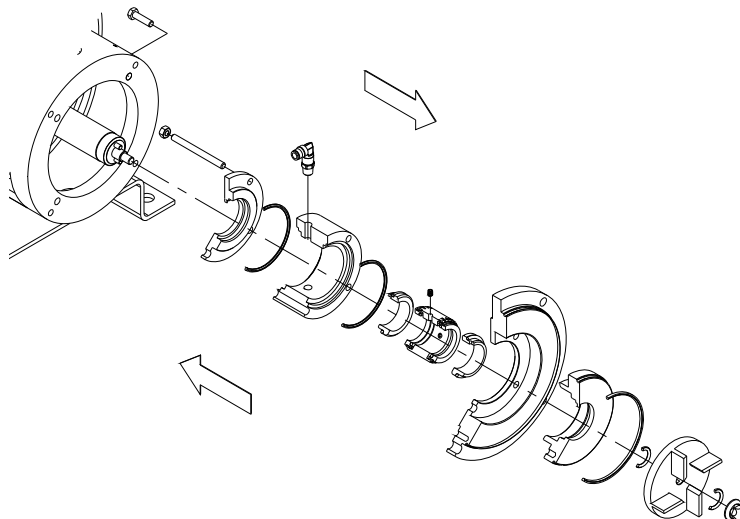

!IMPORTANT! When assembling the new seal, be careful and mount the parts and the O-ring with soapy water in order to allow an easy glide of the parts, either the stationary part and the rotary part on the shaft.

⇐ Assembly

Position the stationary part of the exterior mechanical seal (08D) inside the seal cover (10B) carefully adjusting the fixing pin. Put the o-ring (80F) in the seal cover (10B) and fit it onto the shaft (05A).

Position the rotary part of the mechanical seal on the shaft until adjusting to the assembly measure (see cross section below). Once corresponding to the assembly measure, tighten the nuts of the mechanical seal.

Put the o-rings (80E) and the stationary part of the mechanical seal into the double seal interior cover (10C) and position the threaded rods (55A).

Place the already made assembly into the mixer cover (03) and put the o-ring (80).

Put the o-ring (80F) and the double seal cover (10A) into the double seal interior cover (10C).

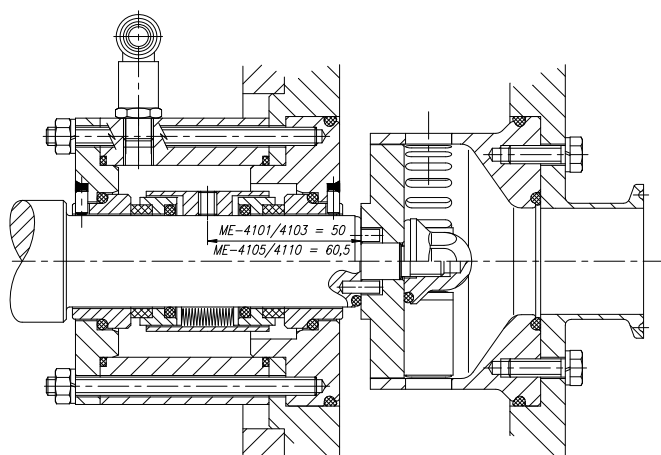

Position the assembly to the lantern (04) with the use of the screws (52A) and the washers (53B).

Slide the seal cover (10B) in order to fit the holes to the threaded rods (55A) and secure the whole group with the corresponding nuts (54).

Before tightening the nuts (54) position the inlet and outlet elbow connections (92) for pressurizing.

Fit the o-ring (80G) and the rotor (21) on the shaft (05).

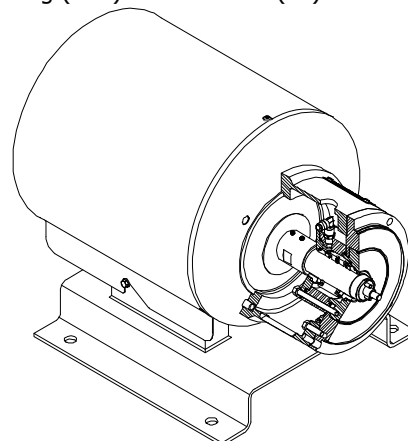

03-400-32.0006

7.4.5. Shaft, lantern and motor

⇒ Disassembly

Take off the shroud (14) by removing the screws that hold it in place.

Take out the screws (52) and washers (53), which secure the lantern (04) to the motor (93). This it will be possible to take the shield from the shroud (14).

Remove the splash ring (82).

Loosen the setscrews (55) in order to take out the shaft (05) and remove the motor from the base plate (38) taking out the screws (52C).

⇐ Assembly

Place the motor (93) onto the base plate (38) and secure it by means of the screws (52C).

Put the mixer shaft (05) in until it meets the motor shaft and secure them by means of the Allen setscrews (55).

Then fit the splash ring (82) onto the shaft.

Place the shroud shield (14) in the motor ridge. Secure the parts by means of the screws (52) and washers (53).

Fit the shroud (14) over the shield and secure with corresponding screws

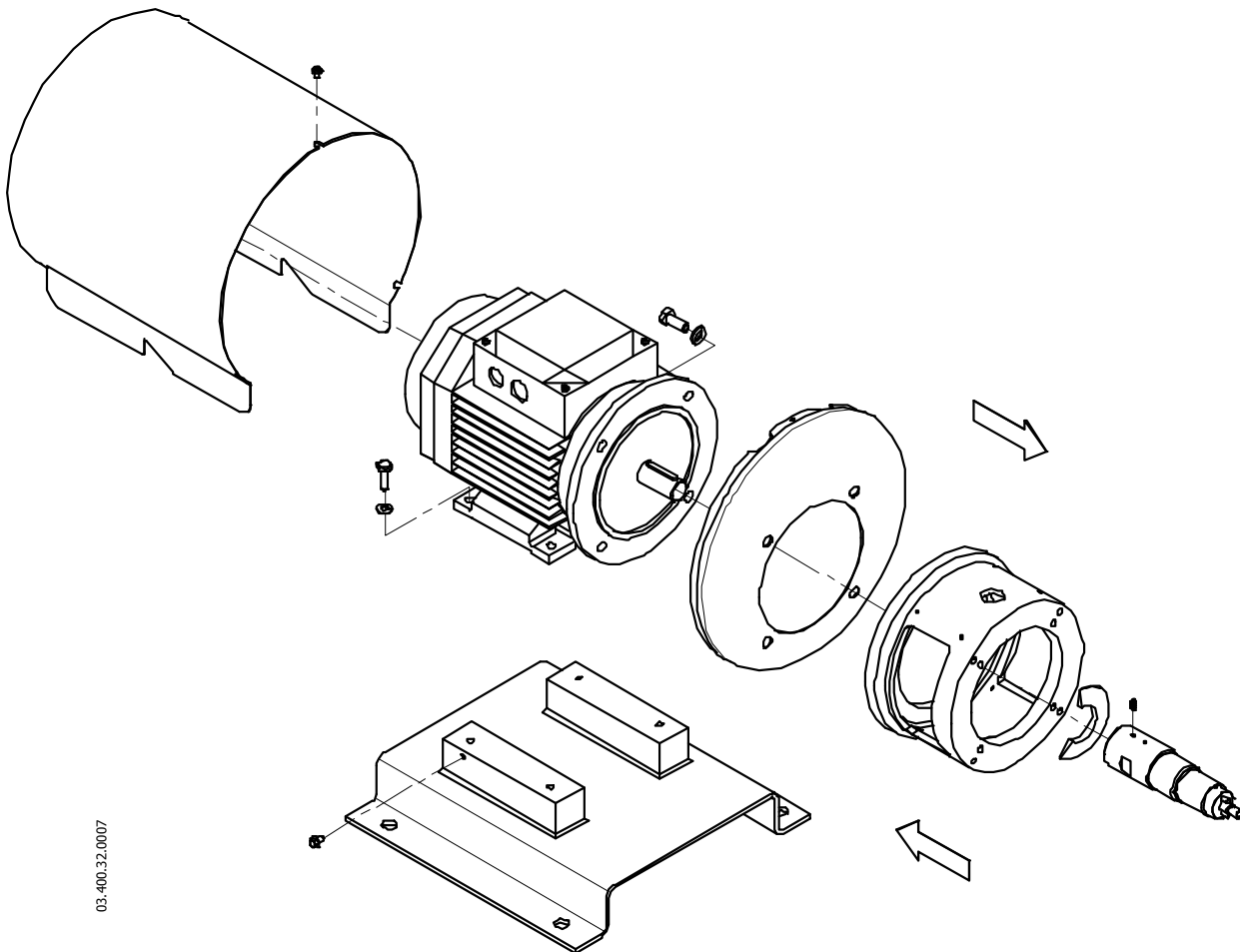

7.5. DISASSEMBLY/ ASSEMBLY OF THE ME-4125/4130 MIXER

7.5.1. Mixer casing and stator

⇒ Disassembly

Remove the mixer from its location.

Clean and dry the Mixer.

Take out the nuts (45A) and remove the cover (03A) and the seal (80B).

Take out the stator (22) from the cover by removing the screws (52B), washers (53C) and seals (80C) and (80D).

Take out the screws (52A) and the washers (53C), which will enable the removal of the mixer casing (01).

⇐ Assembly

Place the seals (80C and 80D) in their position on the stator (22).

Fit the stator onto the cover (03A) and secure the parts by means of the screws (52B) and washers (53C).

Position the seals (80B and 80) in the covers (03) and (03A).

Secure the mixer casing (01) on the lantern (04) by means of the screws (52A) and washers (53B).

Fit the cover (03A) onto the mixer casing and secure by means of the nuts (45A).

Fit the mixer back to its position.

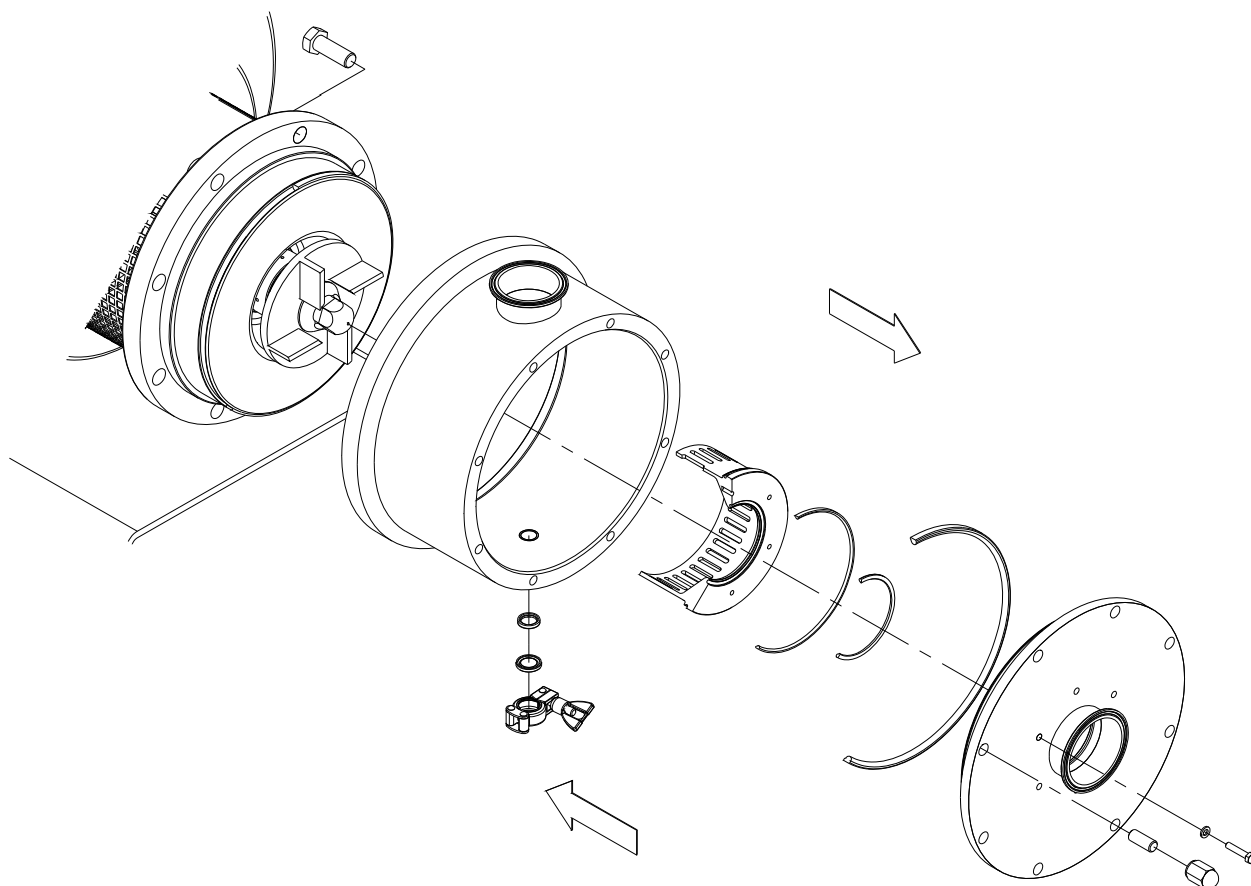

7.5.2. Simple mechanical seal

⇒ Disassembly

Take out the nut (45) and remove the seal (80A), which will enable the taking out of the impeller (21) and the rotary part of the mechanical seal (08).

Remove the protectors (47) by taking out the screws (50).

Remove the cover (03) take out the seal (80) and the stationary part of the mechanical seal.

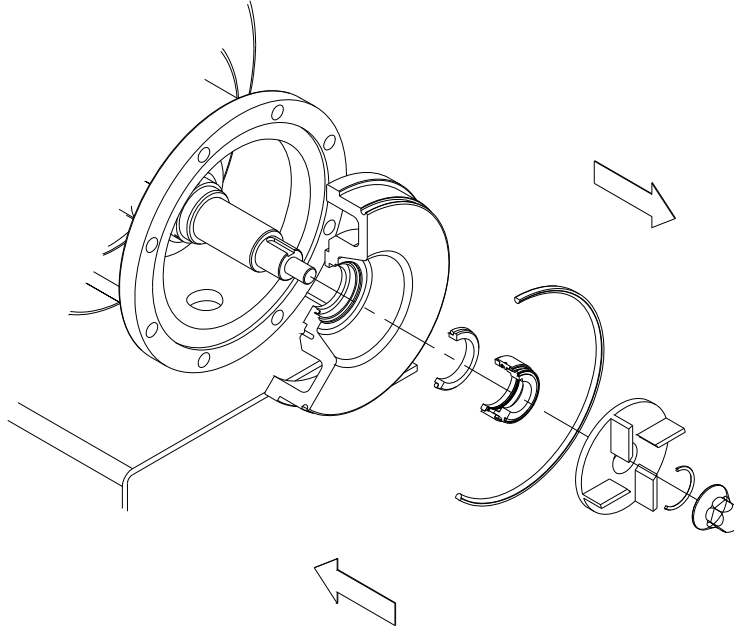

¡IMPORTANT! When assembling the new seal, be careful and mount the parts and the O-ring with soapy water in order to allow an easy glide of the parts, either the stationary part and the rotary part on the shaft.

⇐ Assembly

Fit the cover (03) in its assembly position, bringing it as far as it can go to the lantern (04), and check that the height of the assembly is correct, as indicated below:

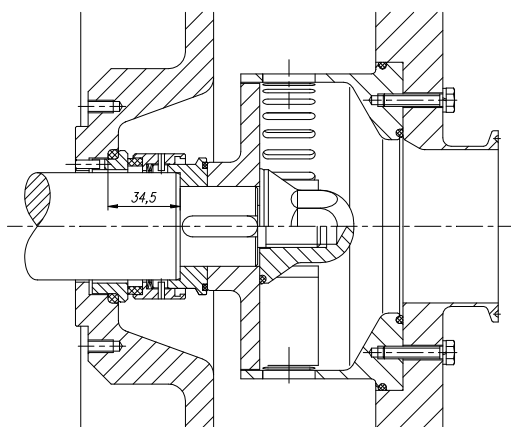

Fit the seal (80) and the stationary part of the seal (08) in the cover (03) taking the stud into account.

Slide the rotating part of the mechanical seal (08) onto the shaft (05) until it reaches the end of same.

Fit the impeller (21) on the shaft and secure it by means of the nut (45), after the seal has been fitted (80A).

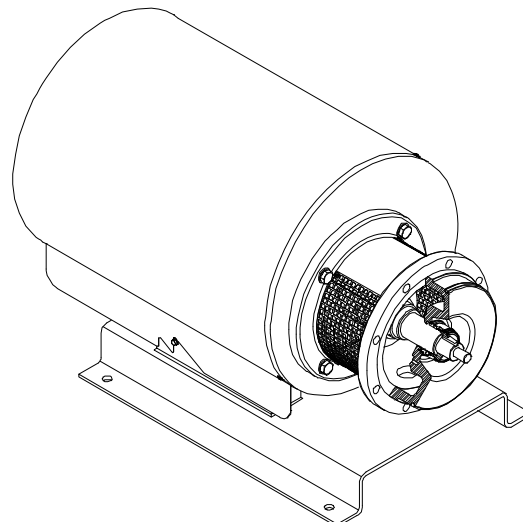

03-400.32.0008

7.5.3. Cooled mechanical seal

⇒ Disassembly

Take out the nut (45) and remove it along with the seal (80A), which will enable the removal of the impeller (21) and the rotary part of the mechanical seal (08).

Remove the cover from the mixer (03) with the ring (30) and the small cover (10) still fitted. The fixed parts of the mechanical seals (08 and 08C) will still be housed in the group.

Take out the screws (52D), thus the fixed part of the exterior seal will come out (08C), as well as the ring (30) and the seal (80E). Then remove the fixed seat from the internal seal (08) of the cover (03).

Loosen the studs (55A) in order to take out the rotary part of the exterior seal (08B).

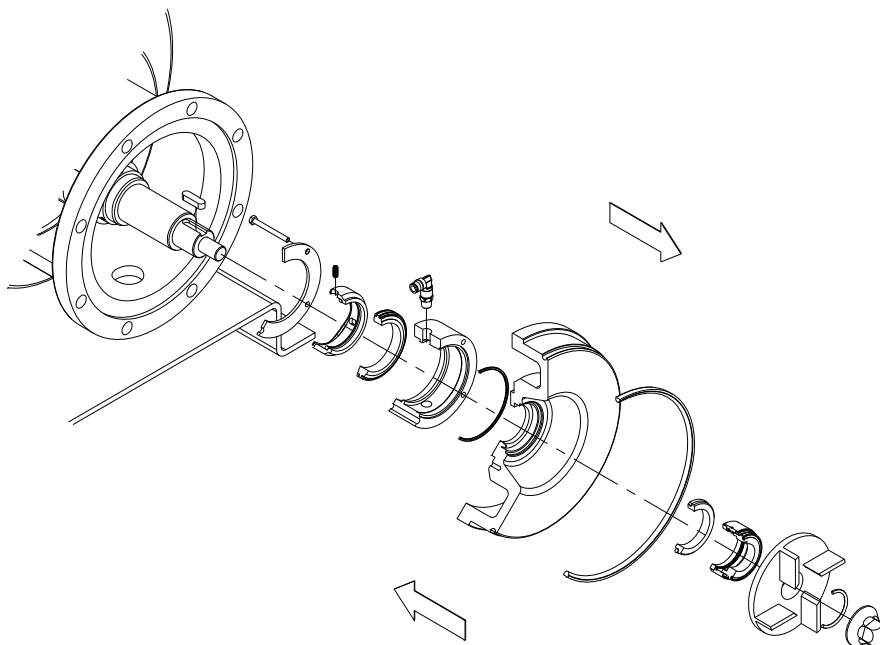

!IMPORTANT! When assembling the new seal, be careful and mount the parts and the O-ring with soapy water in order to allow an easy glide of the parts, either the stationary part and the rotary part on the shaft.

⇐ Assembly

Slide the rotary part of the external seal (08B) over the shaft (05) until it can go no further and secure it with the setscrews.

Fit the stationary part of the external seal (08C) in the double seal cover (10).

Position the seal (80F) in the stud of the cover (03).

Fit the ring (30), the double seal cover (10) and the seal seat (08C) in the cover (03), securing them by means of the screws (52D).

Put the aforementioned assembly carefully into the lantern (04).

Make sure that the assembly height is correct, as indicated below:

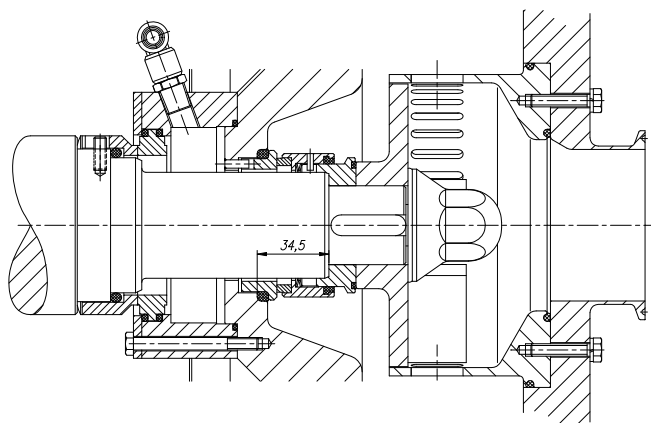

Fit the fixed seat of the seal (08) into the cover (03), followed immediately after by the rotary part of the seal (08) until it can go no further along the shaft (05).

See the section dealing with the fitting of the simple mechanical seal in order to fit the interior mechanical seal.

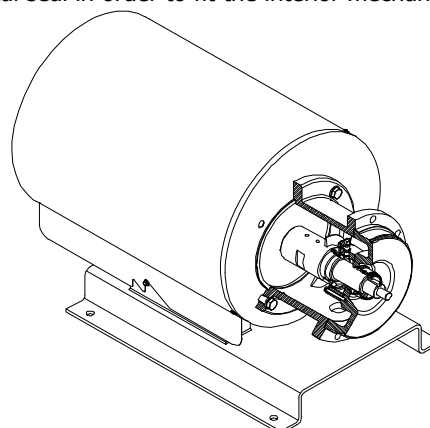

03-400-32-0009

7.5.4. Double mechanical seal

⇒ Disassembly

Remove the nut (45) and take it out along with the seal (80A), which will enable the removal of the impeller (21), the bushing (17) and the seals (80G).

Remove the screws (52D) thus freeing the cover (10B) and take out the set of three covers that have been fitted (03, 10A and 10C).

Loosen the screws (52F) in order to strip the interior cover (10C), the double seal cover (10A) and the mixer cover (03) seal.

Remove the fixed part of the interior mechanical seal (08E) and the seal (80F) which are housed in the interior cover (10C).

Loosen the studs of the rotary parts of the seals, then take out these rotary parts of the mechanical seals (08E and 08D) from the shaft (05).

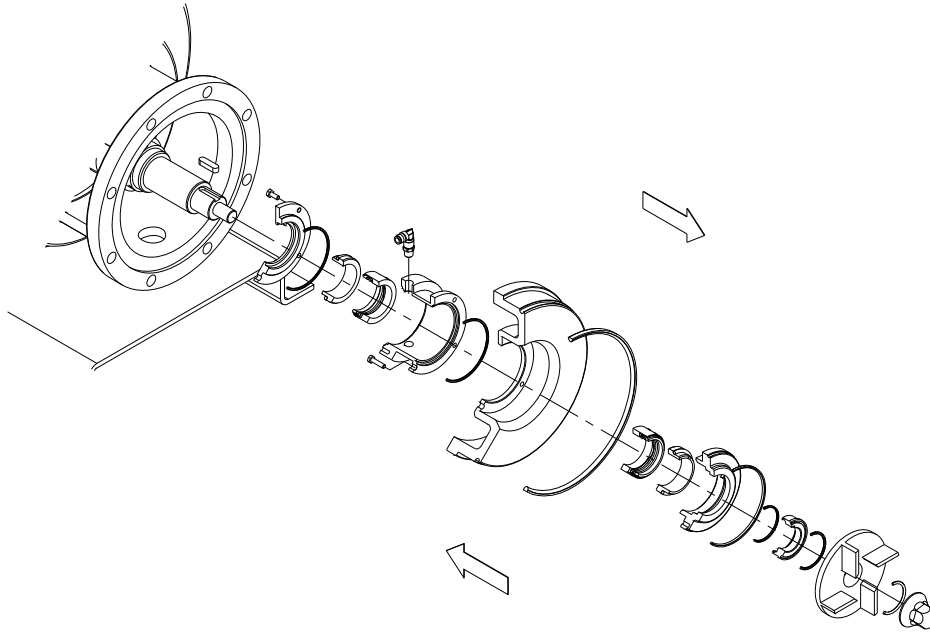

!IMPORTANT! When assembling the new seal, be careful and mount the parts and the O-ring with soapy water in order to allow an easy glide of the parts, either the stationary part and the rotary part on the shaft.

⇐ Assembly

Position the fixed part of the exterior mechanical seal (08D) in the cover lantern (10B), bearing in mind the spindle.

Put the exterior cover (10B) in and leave it loose at the end of the shaft (05).

Position the seal (80E) in the cover (10B).

Slide the rotary part of the exterior mechanical seal (08D) and secure it at the assembly height indicated below.

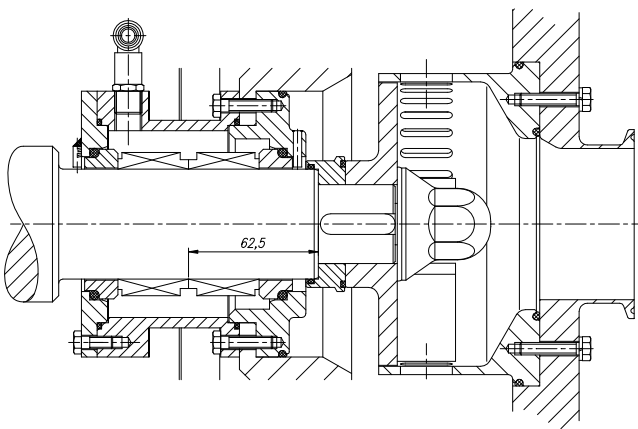

Fit the rotary part of the interior seal (08E) until it goes as far as it can up to the exterior seal (08D) and secure it.

Position the fixed part of the interior seal (08E) in the cover lantern (10C), bearing the spindle in mind.

Fit the covers (03, 10A and 10C) and the seals (80F and 80E) and secure them by means of the screws (52F).

Fit the aforementioned assembly into the lantern (04) and secure the exterior cover (10B) with the screws (53D).

Fit the bushing (17) with the seals (80G) until they can go no further along the shaft (05).

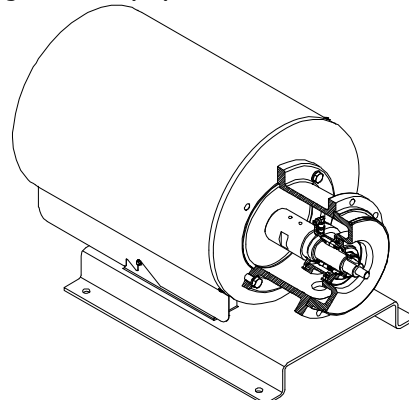

7.5.5. Shaft, lantern and motor

⇒ Disassembly

Take out the screws in order to remove the shield shroud (14).

Take out the screws (52), washers (53 and 53A) and nuts (54) and separate the lantern (04) from the motor flange.

Take out the splash ring (82). Loosen the setscrews (55) and take out the shaft (05).

Finally, loosen the screws (52C) and washers (53D) and separate the motor (93) from the base plate (38).

⇐ Assembly

Position the motor (93) on the base plate (38) and secure it by means of the screws (52C) and washers (53D).

Fit the shaft (05) until it goes as far as it can up to the motor shaft (93) and secure by means of the setscrews (55). Fit the

splash ring (82) onto the shaft (05).

Fit the shield shroud (14) in the motor flange. Secure these parts by means of the screws (52), washers (53 and 53A) and nuts (54).

Fit the shroud (14) over the shield and secure it with the corresponding screws.

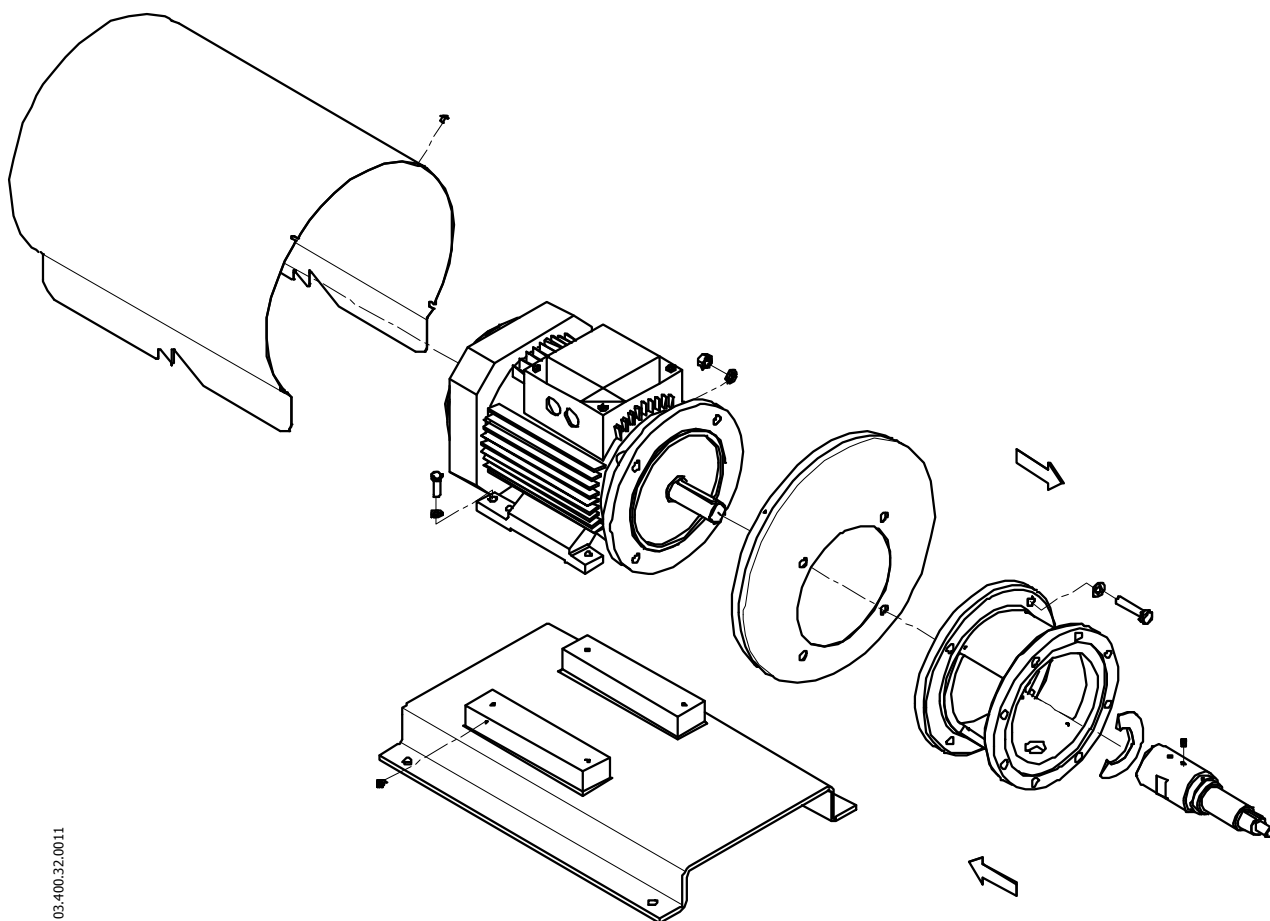

03.400.32.0011

8. Technical Specifications

8.1. TECHNICAL SPECIFICATIONS

Maximum flow rate.....	65 m ³ /h (286 US GPM)
Maximum differential pressure	1 bar (14,5 PSI)
Maximum suction pressure	4 bar (58 PSI)
Operating pressure	-10 °C to +140°C (EPDM) 57 °F to 284 °F (EPDM)
Maximum viscosity (recommended).....	1000 mPa.s.
Maximum speed.....	3000 / 3600 min ⁻¹ (trimmed rotor)
Noise level	60-80 dB(A)
Suction / delivery	Clamp-ISO 2852



Whenever the noise level in the area of operation exceeds 85 dB(A) use special protection.

Materials

Parts in contact with the product	AISI 316L
Other parts in stainless steel	AISI 304
Seals and seals in contact with the product.....	EPDM (standard)
Other optional seal materials	Consult your supplier
Surface finish	Standard finish

Mechanical seal

Type of seal Single internal mechanical seal

Cooled mechanical seal

Maximum pressure	0.5 bar
Consumption.....	6-10 l/min

Double mechanical seal

Maximum pressure 1,5~2 bar (22~29 PSI) over the mixer operating pressure

Mechanical seal materials	Mechanical seal type			
	Inside single	Cooled	Double [atmospheric side]	Double [product side]
Stationary part	Carbon			Silicon carbide
Rotary part	Silicon carbide			

Motor

Standard motor IEC B35 (feet and flange)

2 pole (2900/3500 min⁻¹ to 50/60 Hz) or 4 pole (1450/1750 min⁻¹ to 50/60 Hz) according to model.

Protection	IP55
Connection	3~, 50Hz, 220-240VΔ/380-420VY 3~, 50Hz, 380-420VΔ/660-690VY 3~, 60Hz, To be confirmed

8.2. WEIGHTS

Mixer	Output [kW]	Speed [min ⁻¹]	Weight [Kg]
ME-4101	1.1	2900	51
ME-4103	2.2	2900	65
ME-4105	4	2900	91
ME-4110	7.5	2900	121
ME-4125	18.5	2900	242
ME-4130	22	1450	316

8.3. ME-4100 MIXER DIMENSIONS

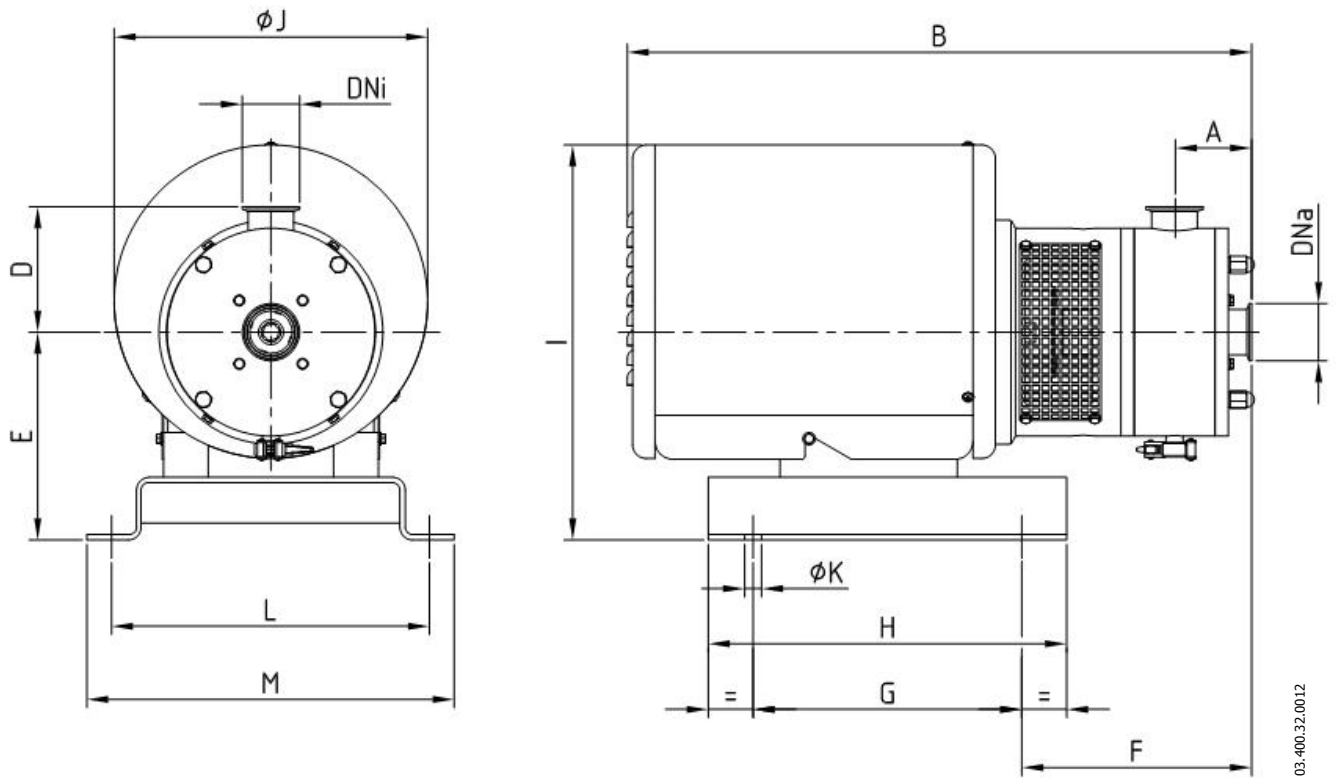

03.400.32.0012

TYPE	DNa	DNi	A	B	D	E	F	G	H	I	ØJ	ØK	L	M
ME-4101	1 ½"	1 ½"	70	595	114	175	190	230	325	355	290	15	245	285
ME-4103				700										
ME-4105	2"	2"	86	700	140	232	256	300	400	445	350	19	355	410
ME-4110	2 ½"	2 ½"		850										
ME-4125	3"	2 ½"	98	1080	175	310	227	600	700	615	500	19	465	520
ME-4130	4"	3"	109	1115	204		269							

Dimensions with CLAMP-ISO 2852 connections

8.4. ME-4101/4103/4105/4110 MIXER

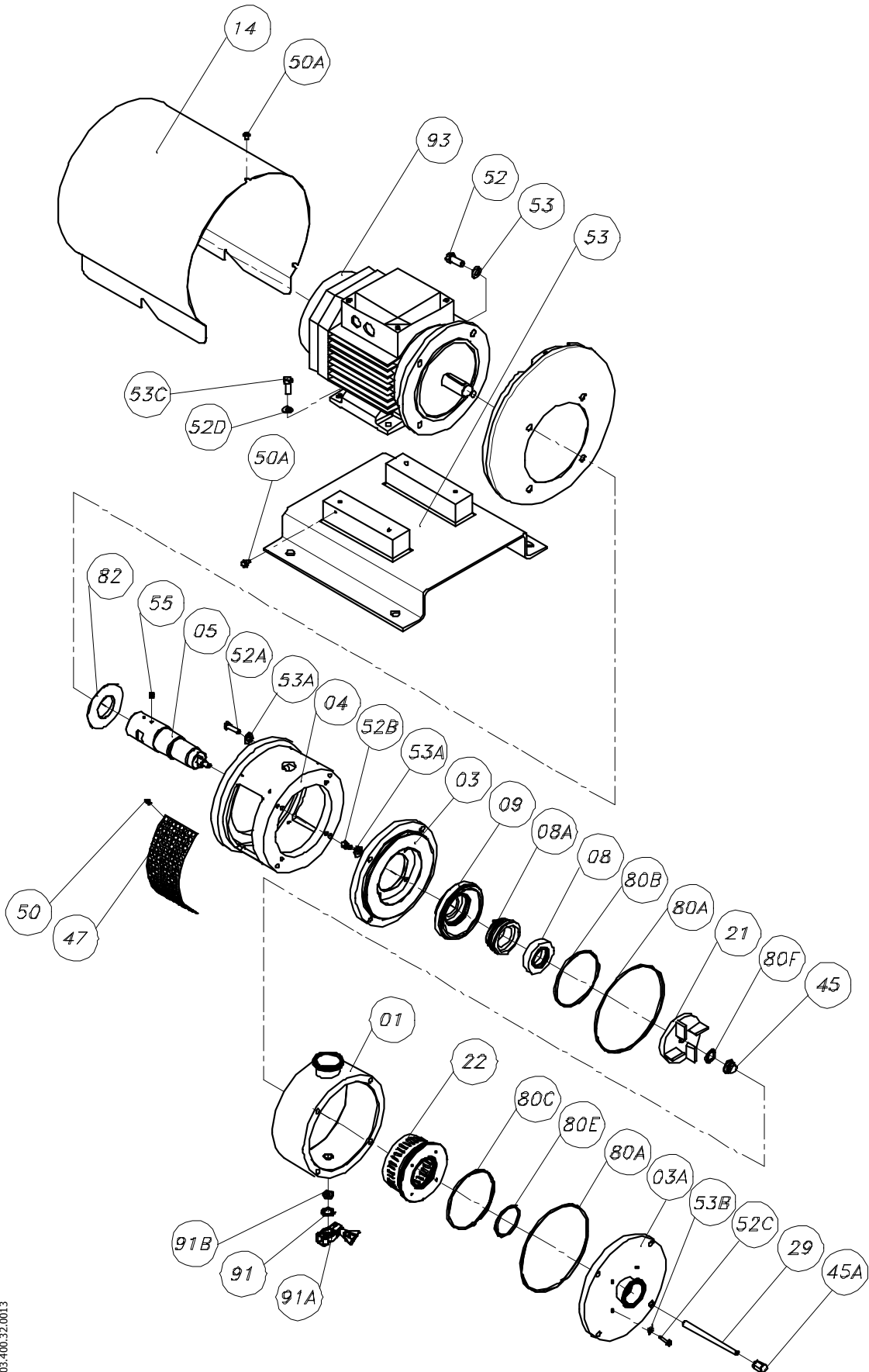

03-400.32.0013

8.5. ME-4101/4103/4105/4110 MIXER

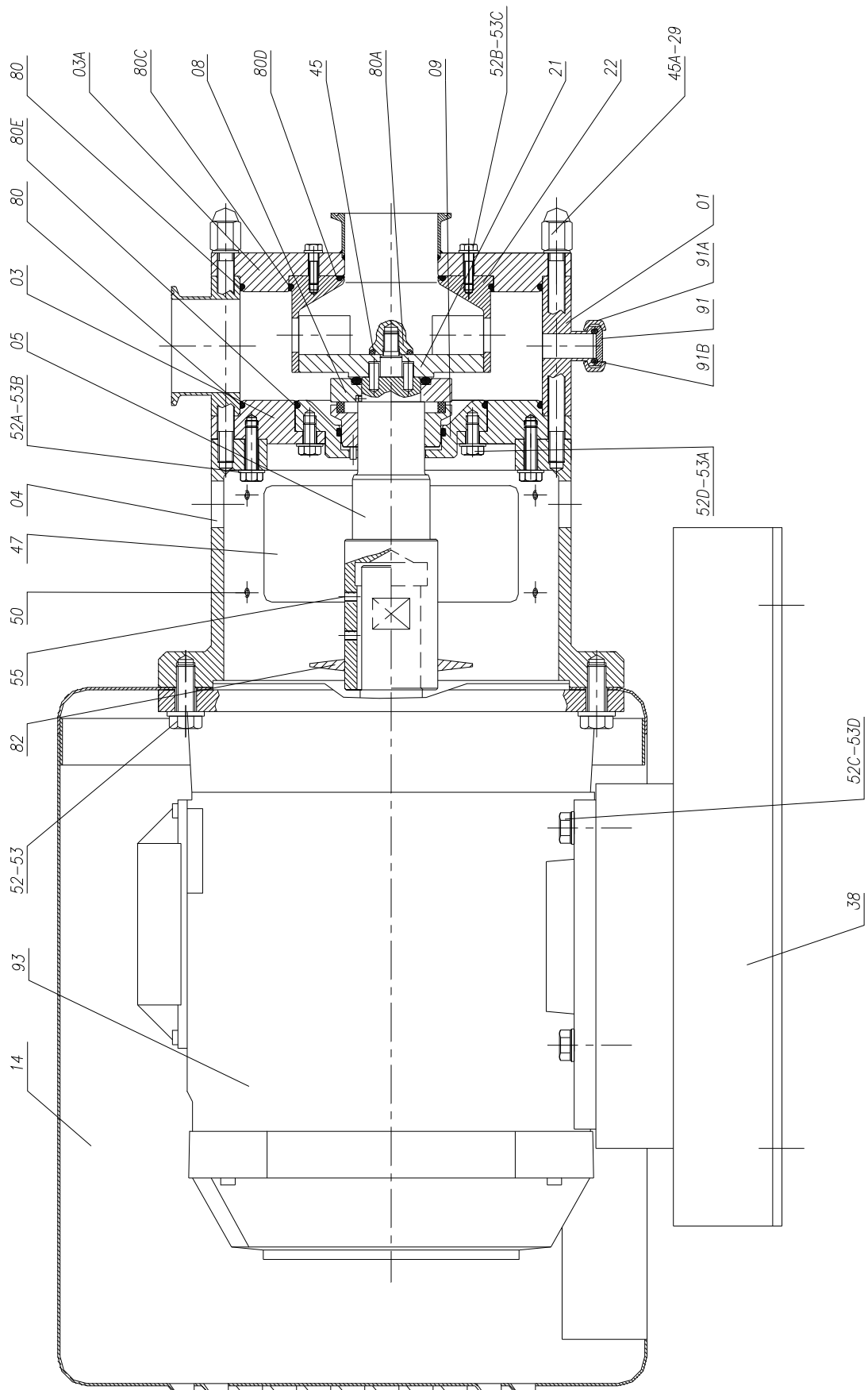

8.6. PARTS LIST ME-4101/4103/4105/4110 MIXER

Position	Description	Quantity	Material
01	Mixer casing	1	AISI-316L
03	Mixer Cover	1	AISI-316L
03A	Mixer front cover	1	AISI-316L
04	Lantern	1	AISI-304
05	Shaft	1	AISI-316L
08	Mechanical seal	1	C / SiC / EPDM
09	Box	1	AISI-316L
14	Shroud	1	AISI-304
21	Rotor	1	AISI-316L
22	Stator	1	AISI-316L
29	Tie rod	4	AISI-304
38	Base plate	1	AISI-304
45	Nut	1	AISI-316L
45A	Nut	4	AISI-304
47	Protector	2	AISI-304
50	Screw	8	A-2
50A	Hexagonal flange screw	5	A-2
52	Hexagonal screw	4	A-2
52A*	Hexagonal screw	4	A-2
52B	Hexagonal screw	4	A-2
52C*	Hexagonal screw	4	A-2
52D	Hexagonal screw	4	A-2
53	Flat washer	4	A-2
53A	Flat washer	4	A-2
53B	Flat washer	4	A-2
53C	Flat washer	4	A-2
53D	Flat washer	4	A-2
55	Stud	2	A-2
80	O-ring	2	EPDM
80A	O-ring	1	EPDM
80C**	O-ring	1	EPDM
80D	O-ring	1	EPDM
80E**	O-ring	1	EPDM
82	Splash ring	1	EPDM
91	Blind bushing clamp	1	AISI-316L
91A	Clamp	1	AISI-316L
91B	Seal	1	EPDM
93	Motor	1	

* ME-4101/4103 : 0 52C units, 8 52A units

** ME-4101/4103 : 0 80E units, 2 80C units

8.7. ME-4125/4130 MIXER

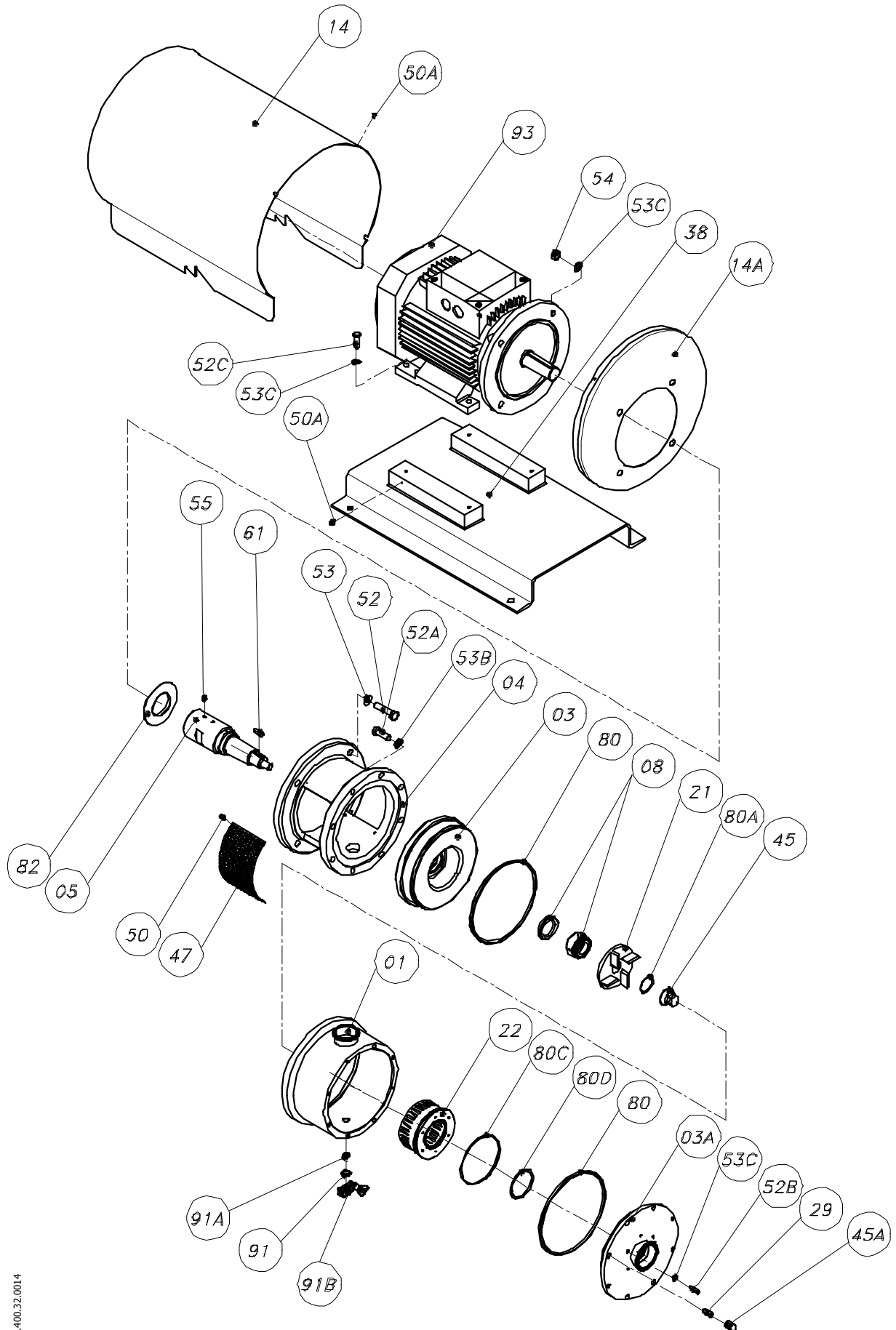

03.400.32.001.4

8.8. ME-4125/4130 MIXER

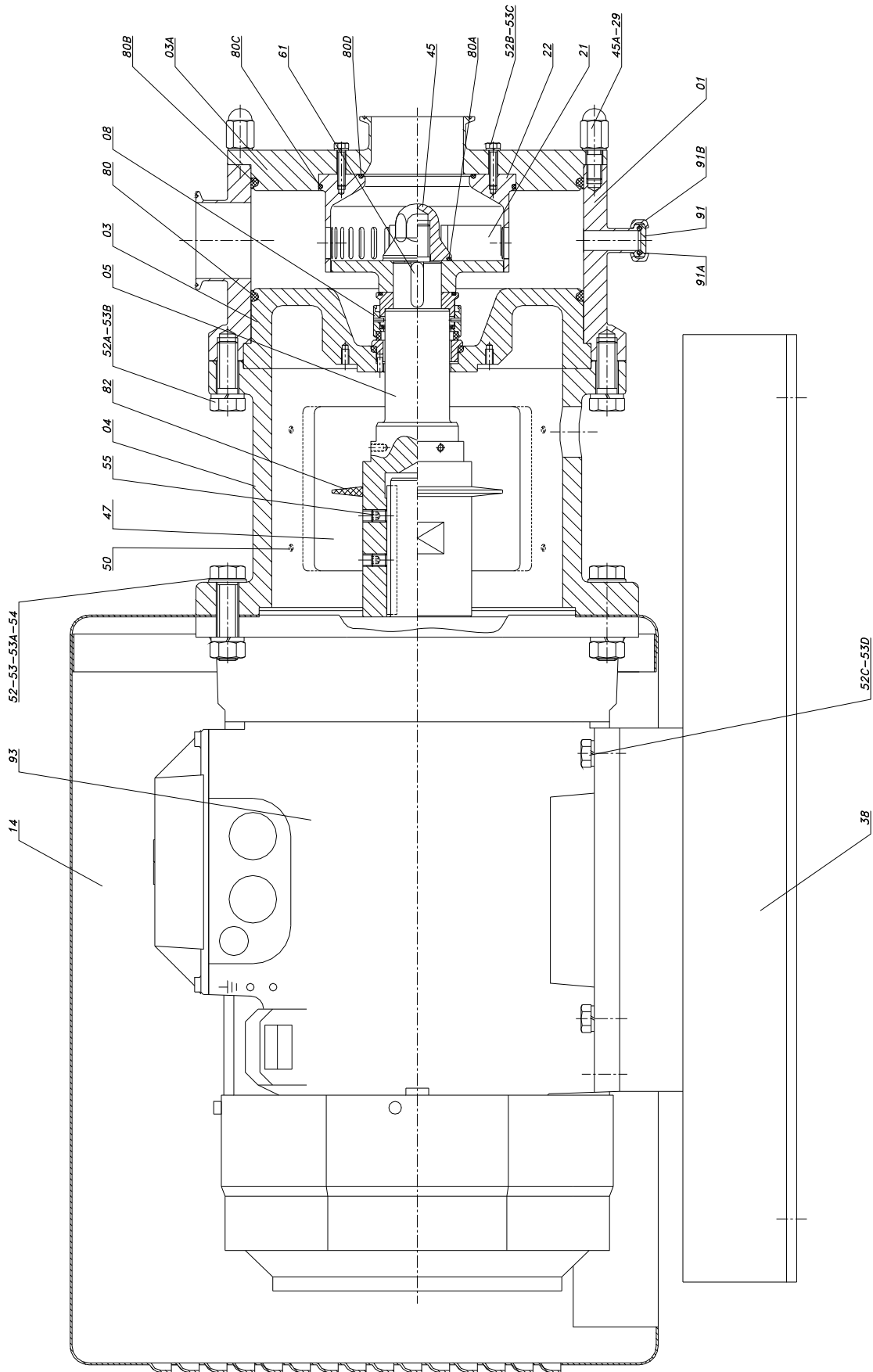

8.9. PARTS LIST ME-4125/4130 MIXER

Position	Description	Quantity	Material
01	Mixer casing	1	AISI-316L
03	Mixer Cover	1	AISI-316L
03A	Mixer front cover	1	AISI-316L
04	Lantern	1	AISI-304
05	Shaft	1	AISI-316L
08	Mechanical seal	1	C / SiC / EPDM
14	Shroud	1	AISI-304
21	Rotor	1	AISI-316L
22	Stator	1	AISI-316L
29	Tie rod	4	AISI-304
38	Base plate	1	AISI-304
45	Nut	1	AISI-316L
45A	Nut	8	AISI-304
47	Protector	2	AISI-304
50	Screw	8	A-2
50A	Hexagonal flange screw	6	A-2
52	Hexagonal screw	4	A-2
52A	Hexagonal screw	8	A-2
52B	Hexagonal screw	6	A-2
52C	Hexagonal screw	4	A-2
53	Flat washer	4	A-2
53A	Flat washer	4	A-2
53B	Flat washer	8	A-2
53C	Flat washer	6	A-2
53D	Flat washer	4	A-2
54	Nut	4	A-2
55	Stud	2	A-2
61	Pin	1	AISI-316L
80*	O-ring	1	EPDM
80A	O-ring	1	EPDM
80B*	O-ring	1	EPDM
80C	O-ring	1	EPDM
80D	O-ring	1	EPDM
82	Splash ring	1	EPDM
91	Blind bushing	1	AISI-316L
91A	Clamp	1	AISI-316L
91B	Seal	1	EPDM
93	Motor	1	

* ME-4125: 2 80 units, 0 80B units

8.10. ME-4101/4103/4105/4110 MIXER COOLED MECHANICAL SEAL

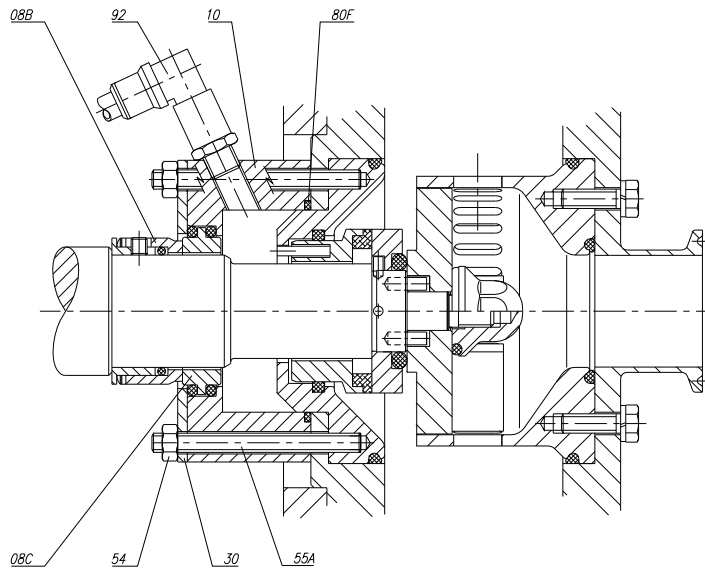

Position	Description	Quantity	Material
08B	Mechanical seal - rotary part -	1	SiC / EPDM
08C	Mechanical seal - stationary part -	1	C / EPDM
10	Seal cover	1	AISI-316L
30	Sealing ring	1	AISI-316L
54	Nut	4	A2
55A	Threaded rod	4	A2
80F	O-ring	1	EPDM
92	Elbow connection	2	AISI-316L

8.11. ME-4125/4130 MIXER COOLED MECHANICAL SEAL

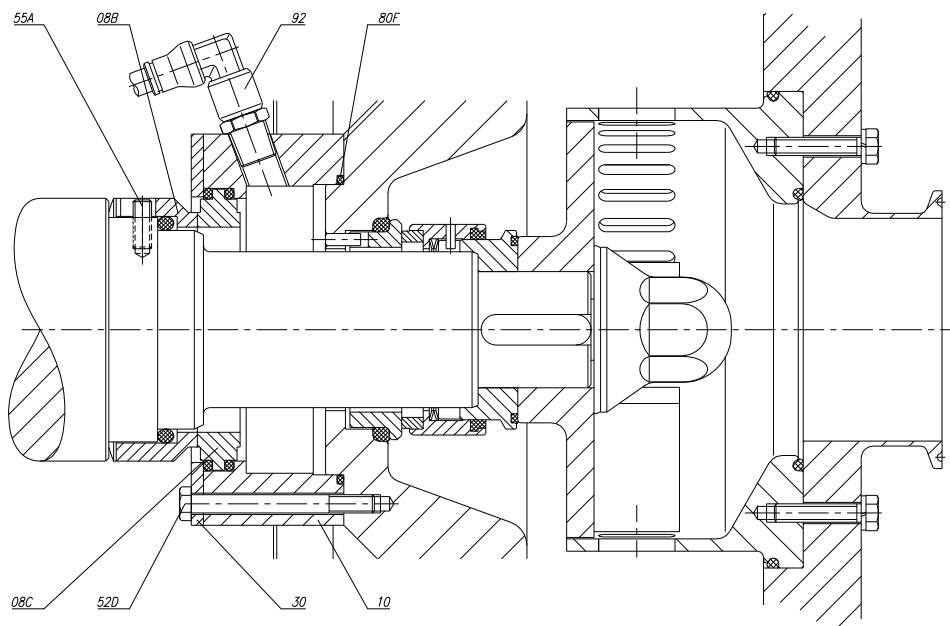

Position	Description	Quantity	Material
08B	Mechanical seal - rotary part -	1	SiC / EPDM
08C	Mechanical seal - stationary part -	1	C / EPDM
10	Seal cover	1	AISI-316L
30	Sealing ring	1	AISI-316L
52D	Hexagonal screw	4	A2
55A	Stud	3	A2
80F	O-ring	1	EPDM
92	Elbow connection	2	AISI-316L

8.12. ME-4101/4103/4105/4110 MIXER DOUBLE MECHANICAL SEAL

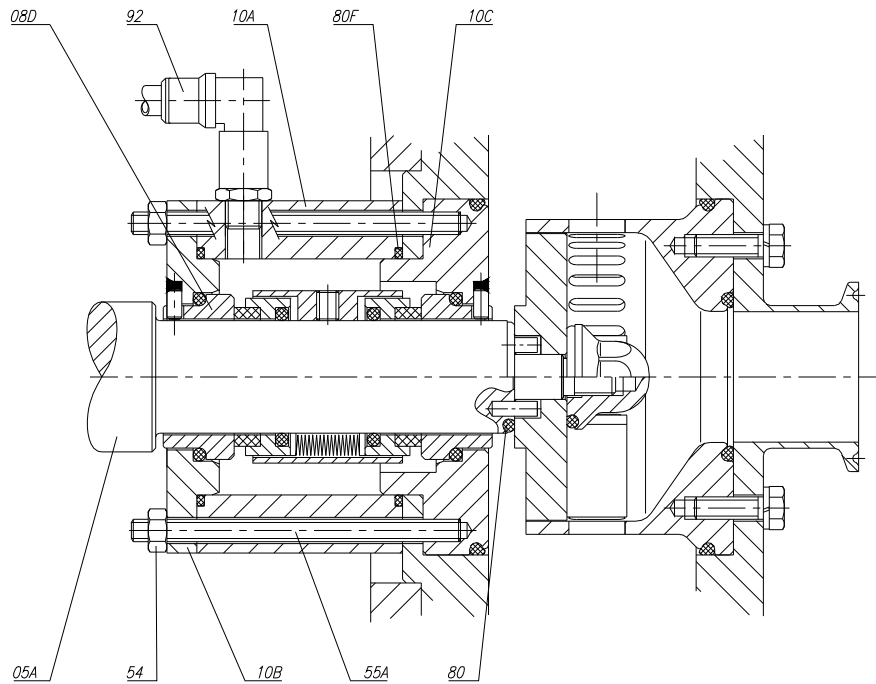

Position	Description	Quantity	Material
05A	Double seal shaft	1	AISI-316L
08D	Double mechanical seal	1	SiC / SiC / EPDM SiC / C/ EPDM
10A	Double seal cover	1	AISI-316L
10B	Double seal cover	1	AISI-316L
10C	Double seal interior cover	1	AISI-316L
54	Nut	4	A2
55A	Threaded rod	4	A2
80	O-ring	1	EPDM
80F	O-ring	2	EPDM
92	Elbow connection	2	AISI-316

8.13. ME-4125/4130 MIXER DOUBLE MECHANICAL SEAL

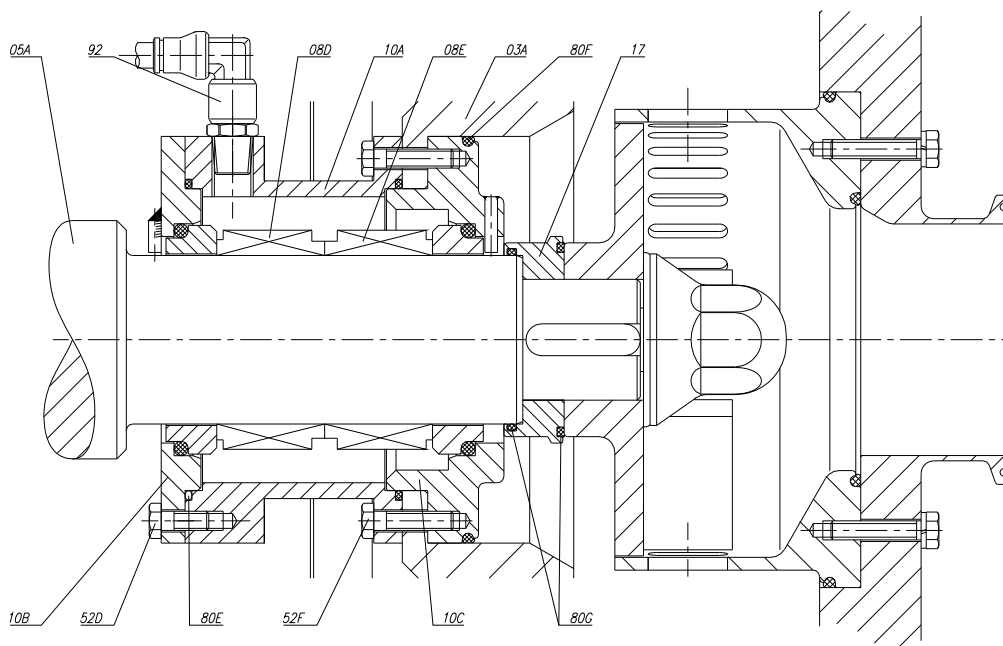

Position	Description	Quantity	Material
03A	Double seal mixer cover	1	AISI-316L
05A	Double seal shaft	1	AISI-316L
08D	Mechanical seal	1	SiC / C / EPDM
08E	Mechanical seal	1	SiC / SiC / EPDM
10A	Double seal cover	1	AISI-316L
10B	Double seal cover	1	AISI-316L
10C	Double seal interior cover	1	AISI-316L
17	Separator	1	AISI-316L
52D	Hexagonal screw	4	A2
52F	Hexagonal screw	4	A2
80E	O-ring	2	EPDM
80F	O-ring	1	EPDM
80G	O-ring	2	EPDM
92	Elbow connection	2	AISI-316

**INOXPA, S.A.**

c/ Telers, 54 – PO Box 174
17820 BANYOLES (GIRONA)
Tel: 34 972575200
Fax: 34 972575502
e-mail: inoxpa@inoxpa.com
www.inoxpa.com

DELEGACIÓN STA

GALDACANO (BILBAO)
Tel: 944 572 058
Fax: 944 571 806
e-mail: sta@inoxpa.com

DELEGACIÓN CENTRO

ARGANDA DEL REY (MADRID)
Tel: 918 716 084
Fax: 918 703 641
e-mail: inoxpa.centro@inoxpa.com

INOXPA SOLUTIONS LEVANTE

PATERNA (VALENCIA)
Tel: 963 170 101
Fax: 963 777 539
e-mail: isf@inoxpa.com

INOXPA COLOMBIA SAS

BOGOTA
Tel: 571 4208711
Fax: 571 4190562
e-mail: colombia@inoxpa.com

INOXPA ALGERIE

ROUIBA
Tel: 213 21856363 / 21851780
Fax: 213 21854431
e-mail: inoxpalgerie@inoxpa.com

INOXPA UK LTD

SURREY
Tel: 44 1737 378 060 / 079
Fax: 44 1737 766 539
e-mail: inoxpa-uk@inoxpa.com

INOXPA SKANDINAVIEN A/S

HORSENS (DENMARK)
Tel: 45 76 286 900
Fax: 45 76 286 909
e-mail: inoxpa.dk@inoxpa.com

**INOXPA SPECIAL PROCESSING
EQUIPMENT, CO., LTD.**

JIAXING (China)
Tel.: 86 573 83 570 035 / 036
Fax: 86 573 83 570 038

INOXPA UCRANIA

KIEV
Tel: 38 050 720 8692
e-mail: kiev@inoxpa.com

DELEGACIÓN NORD-ESTE

BARBERÀ DEL VALLÈS (BCN)
Tel: 937 297 280
Fax: 937 296 220
e-mail: inoxpa.nordeste@inoxpa.com

LOGROÑO

Tel: 941 228 622
Fax: 941 204 290
e-mail: sta.rioja@inoxpa.com

DELEGACIÓN SUR

JEREZ DE LA FRONTERA (CÁDIZ)
Tel / Fax: 956 140 193
e-mail: inoxpa.sur@inoxpa.com

INOXPA SOLUTIONS FRANCE

GLEIZE
Tel: 33 474627100
Fax: 33 474627101
e-mail: inoxpa.fr@inoxpa.com

INOXPA MIDDLE EAST FZCO

DUBAI - U.A.E
Tel. +971 (0)4 372 4408
sales.ae@inoxpa.com

INOXPA SOUTH AFRICA (PTY) LTD

JOHANNESBURG
Tel: 27 117 945 223
Fax: 27 866 807 756
e-mail: sales@inoxpa.com

S.T.A. PORTUGUESA LDA

VALE DE CAMBRA
Tel: 351 256 472 722
Fax: 351 256 425 697
e-mail: comercial.pt@inoxpa.com

IMPROVED SOLUTIONS PORTUGAL LDA

VALE DE CAMBRA
Tel: 351 256 472 140 / 138
Fax: 351 256 472 130
e-mail: isp.pt@inoxpa.com

INOXRUS

MOSCOW (RUSIA)
Tel / Fax: 74 956 606 020
e-mail: moscow@inoxpa.com

DELEGACIÓN LEVANTE

PATERNA (VALENCIA)
Tel: 963 170 101
Fax: 963 777 539
e-mail: inoxpa.levante@inoxpa.com

LA CISTÉRNIGA (VALLADOLID)

Tel: 983 403 197
Fax: 983 402 640
e-mail: sta.valladolid@inoxpa.com

CHAMBLY (PARIS)

Tel: 33 130289100
Fax: 33 130289101
e-mail: isf@inoxpa.com

INOXPA AUSTRALIA PTY (LTD)

MORNINGTON (VICTORIA)
Tel: 61 3 5976 8881
Fax: 61 3 5976 8882
e-mail: inoxpa.au@inoxpa.com

INOXPA USA, Inc

SANTA ROSA
Tel: 1 7075 853 900
Fax: 1 7075 853 908
e-mail: inoxpa.us@inoxpa.com

INOXPA ITALIA, S.R.L.

BALLO DI MIRANO – VENEZIA
Tel: 39 041 411 236
Fax: 39 041 5128 414
e-mail: inoxpa.it@inoxpa.com

INOXPA INDIA PVT. LTD.

Maharashtra, INDIA.
Tel: 91 2065 008 458
inoxpa.in@inoxpa.com

SAINT PETERSBURG (RUSIA)

Tel: 78 126 221 626 / 927
Fax: 78 126 221 926
e-mail: spb@inoxpa.com

INOXPA products are available from our branch offices and through a network of independent distributors covering more than 50 countries around the World. For more information, visit our Web site: www.inoxpa.com

This information is given for guidance only. We reserve the right to change any materials or characteristics without prior notice