

HS-13MHHS THREE SEGMENT CLAMPS

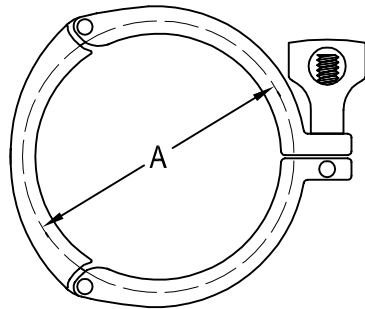

TUBE OD	Max. Pressure psig @ 70°F ¹	Max. Pressure psig @ 250°F ¹	A	SS-304 Item No.
1" - 1½"	600	300	2.130	1.00"-1.50" HS-13MHHS-4-7
2"	550	275	2.630	2.00" HS-13MHHS-4-7
2½"	450	225	3.160	2.50" HS-13MHHS-4-7
3"	350	175	3.700	3.00" HS-13MHHS-4-7
4"	300	150	4.790	4.00" HS-13MHHS-4-7

Note 1 : Wing nut tightened to 25 in. lb. of torque

All dimensions in inches.



www.halesoninc.com