

The Murzan PI 50 Sanitary Pump Gently Handles the Widest Range of Viscosities and Particle Sizes Up to 6" (15 cm).

The **Murzan PI 50** is the only diaphragm pump specifically designed to meet the special requirements of the sanitary industry. High efficiency oil free air valve, maintenance free ball check system or flap check valve and total visual inspection of all wetted parts, give the user safe and efficient transfer of foods, cosmetics and pharmaceuticals — USDA listed, FDA approved, the PI 50 Series is manufactured to meet general 3-A standards.

Construction

PI 50 DL — 304 SS Wetted Parts

PI 50 SL — 316L SS Wetted Parts

All wetted parts polished to number 4 finish — 180 grit. Even non-wetted parts such as air chambers are also polished. Valve center block on all models is 316SS. Food grade BUNA N is standard for diaphragms, gaskets and valve balls; other elastomers are also available. The base is constructed of polished 304SS and is equipped with rubber feet. (Casters optional)

Suction and Discharge

Tri-clamp sanitary connection standard, other connection types optional. Sizes: 2"x2"; 3"x2"; 3"x3"; 4"x4"; and 6"x6". Ball check valves or flap check valves.

Ease of Cleaning

Our unique design allows for total visual inspection of all wetted parts. There are no blind spots or hidden areas for bacteria to grow in. Simply remove the manifold clamps and chamber clamps for complete disassembly and cleaning. Our sanitary speed clamps reassemble the PI 50 in minutes for a minimum of down time. Easy to sterilize and to clean in place (C.I.P.).

Exclusive Ball Check System*

Exclusive Ball Check System utilizes the product chambers on the discharge and the intake manifolds as a unibody valve seat. There is no need for costly and troublesome removable ball seats. Stalling is prevented by the tapered design of the ball check. Product cannot be trapped between the ball and seat, therefore, there is no stalling problem with the PI 50 SL Series.

Oil Free Air Valve

The PI 50 oil free air valve needs no lubrication. The possibility of environmental contamination is totally eliminated. Constructed of Teflon and Stainless Steel, the valve operates horizontally with a minimum of frictional losses. This patented feature allows the valve to activate under a 10 PSI differential pressure. The efficiency of the valve gives high performance at lower input air pressure. The result is a lower cost to you per gallon of product pumped.

Anti-Freezing Design*

Our mechanically activated and adjustable anti-freezing feature allows our valve to function perfectly under the most adverse operating conditions. With the PI 50 there is no need to add anti-freezing solutions to the air supply. No possibility of environmental contamination caused by these additives.

Advantages of the PI 50 DL

- Self priming up to 24 feet
- Costly drives and special motors are not required
- No mechanical seals to replace
- Light in weight, 94 lbs. — it can be moved to the application
- Run dry without damage
- Fewer parts than other available pumps
- For portable & permanent installations
- Infinitely variable flow control
- Solids up to 6" (15 cm)
- Abrasives
- Shear Sensitive Fluids
- Viscosities up to 150,000 CP

Applications Like:

- Cottage Cheese
- Frozen Concentrate Orange Juice
- Yogurt • Ice Cream Toppings
- Tomato Paste
- Vegetable Soups
- Diced Tomatoes
- Ground Beef
- Pineapple Chunks
- Pie Fillings
- Fruit Juice Concentrate
- Relish • Catsup

- Chicken Livers and Gizzards
- Macaroni Salad
- Yeast • Eggs
- Barbecue Sauces
- Salad Dressings
- Mustard • Mayonnaise

Industries

- Food Industry
- Dairy Products
- Meat & Poultry
- Beverage
- Egg Processing Plants
- Cosmetics
- Pharmaceuticals
- Chemicals



MURZAN PI 50

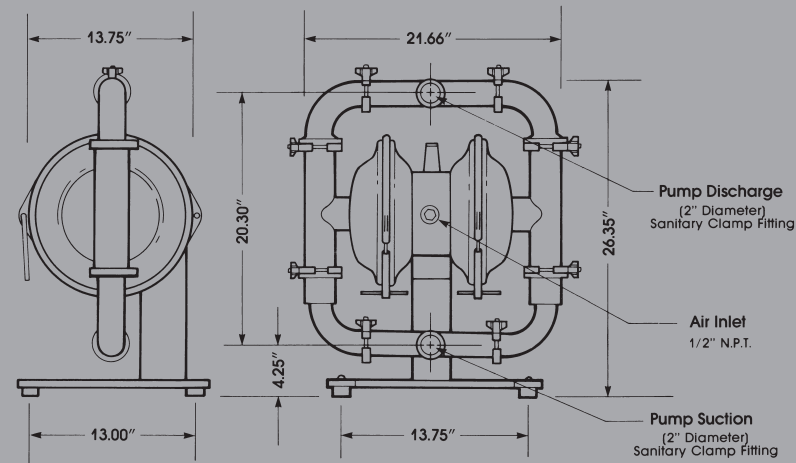
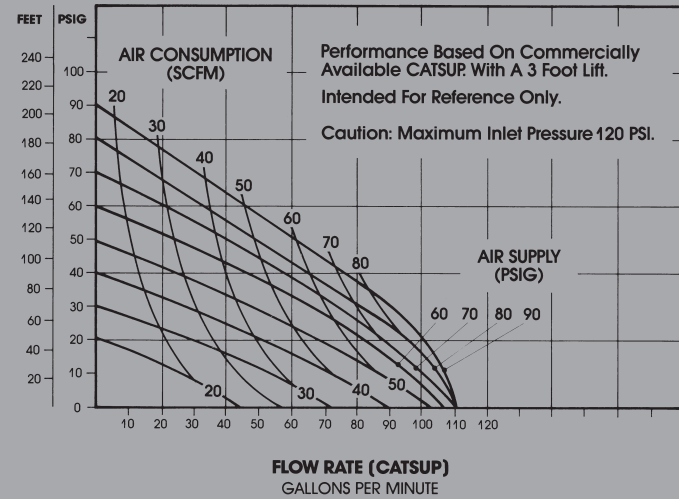
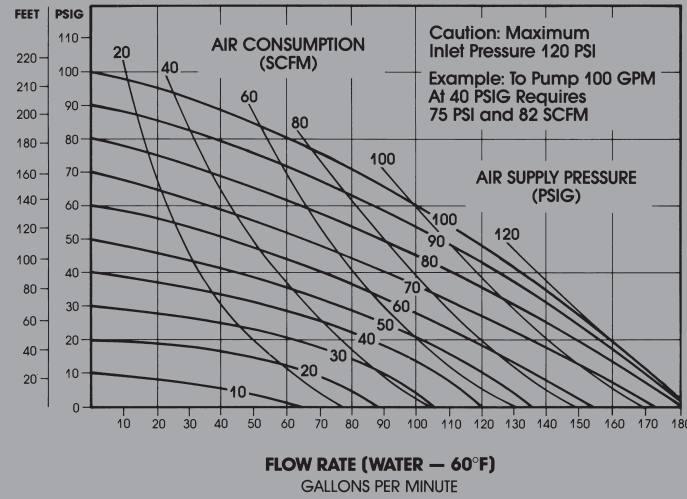

MURZAN

SANITARY PUMPS



MURZAN

Murzan, Inc.
 2909 Langford Rd. 1-700
 Norcross, GA 30071
 U.S.A.
 Tel: (770) 448-0583
 Fax: (770) 448-0967
 email: murzan@murzan.com

Murzan Europe, SARL
 Orly Frêt BP 617
 Zone Juliette Bât. 127-D
 94392 Orly Aéroport Cedex
 FRANCE
 Tel: (331) 49755152
 Fax: (331) 49755153
murzaneurope@murzan.com

Murzan Mexico, S.A.
 Coscomate 199
 04730 México, D.F.
 MEXICO
 Tel: (525) 528-2384
 Fax: (525) 665-2217
ventas@murzanmexico.com.mx

*Patent Pending

Printed in U.S.A.