

SVA: STERILE ACCESS BLOCK VALVE

Barstock Single Block Valve with Single or Double Sterile Access, Manual or Pneumatically Actuated

SPECIFICATIONS AND FEATURES*

Available Sizes:

- » Run Connections: 1/2" - 4" (DN15 - DN100)
- » Access Port Connection: 1/2" - 4" (DN15 - DN100); drop connection must be \leq the run connection

Connection Type:

- » ASME BPE Tri-clamp, Extended Tube End standard. Additional connection types available as options upon request
- » Sample port configurations available as special options

Materials:

- » Standard: Barstock, ASME SA479 316L (UNS 31603) or EN 10272:2000 GR 1.4435
- » Optional: AL-6XN®, Hastelloy® C-22 and others readily available

Surface Finish:

- » Wetted Interior:
 - Standard:
 - ASME BPE SF1, 20 Ra μm (0,5 Ra μm)
 - ASME BPE SF5, 20 Ra μm (0,5 Ra μm) Electropolish.
 - Optional:
 - ASME BPE SF4, 15 Ra μm (0,4 Ra μm) Electropolish. Better finish upon request
- » Exterior:
 - Standard: 40 Ra μm (1,0 Ra μm) and better as option
 - Optional: 20 Ra μm (0,5 Ra μm) and better upon request

* See last 2 pages of this data sheet for GENERAL FEATURES, SPECIFICATIONS and DOCUMENTATION supplied regarding all of our diaphragm valves

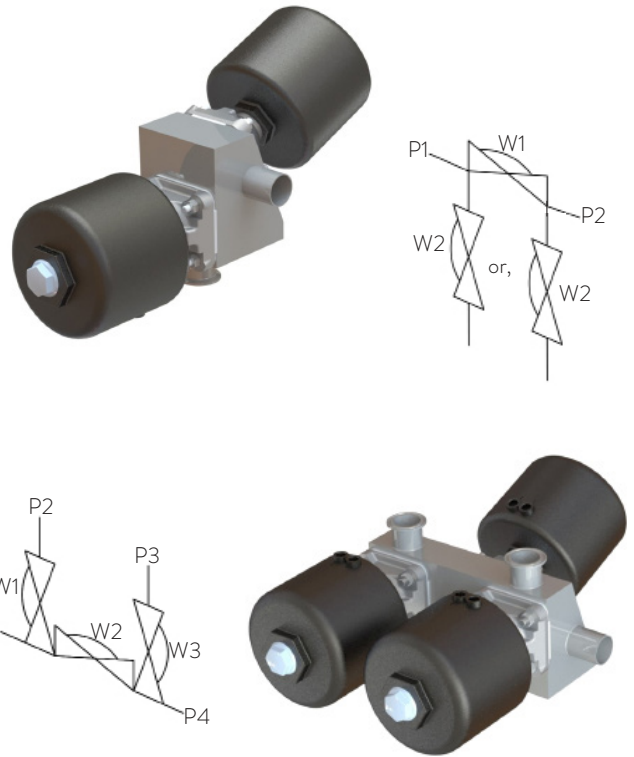

APPLICATIONS

Single Block Valve with Single or Double Sterile Access valves for manual on/off or Air Actuated Flow Control for Transfer, Diversion or Sample of Drug Process Additives, WFI and other critical system fluids

- » Upstream:
 - Bioreactor/Fermenter: For sampling or transfer of critical process fluids, inputs or WFI upstream of, and prior to opening the main valve
- » Downstream:
 - For sampling or transfer of critical process fluids, buffers, or WFI upstream of and prior to, opening the main valve in the following areas:
 - Separation
 - Filtration
 - Chromatography
 - Formulation
 - Fill Finish
- » Buffer and Media Prep:
 - For sampling or transfer of critical process fluids, buffers or WFI upstream of, and prior to opening the main valve

BONNET / ACTUATOR SPECIFICATIONS

Manual Bonnet Assembly:

- » Available for sizes: 1/2" - 4" (DN15 - DN100)
- » Closing Stop: adjustable
- » Bright visual position indicator
- » Options: contact factory for proximity switches, locking devices and stroke limiter

Bonnet Materials

- » Bonnet: electropolished Stainless Steel
- » Compressor: Stainless Steel
- » Insert: brass
- » Thrust Washer: PTFE
- » Compressor Pin: Stainless Steel
- » Indicator: Polyolefin
- » Stem: Stainless Steel
- » Handwheel: PPS (1/4" - 2") (DN8 - DN50); Stainless Steel (2-1/2" - 4") (DN65 - DN100)

Air Actuated Bonnets:

- » Available for sizes: 1/2" - 2" (DN15 - DN50) standard; 3" & 4" (DN80 & DN100) optional
- » Air Actuator Materials: Polyamide, Stainless Steel, Stainless Steel base standard for all configurations
- » Actuator Seal: Actuator springs and seals can be replaced without exposing process
- » Orientation: Swivel feature allows 360° orientation of air inlet
- » Air Connections: NPT Stainless Steel base standard for all configurations
- » Function: Change from Normally Open or Normally Closed by inverting the actuator housing
- » Control System Interface: Available with optional switch packages for on/off control or with positioners for flow control and modulation

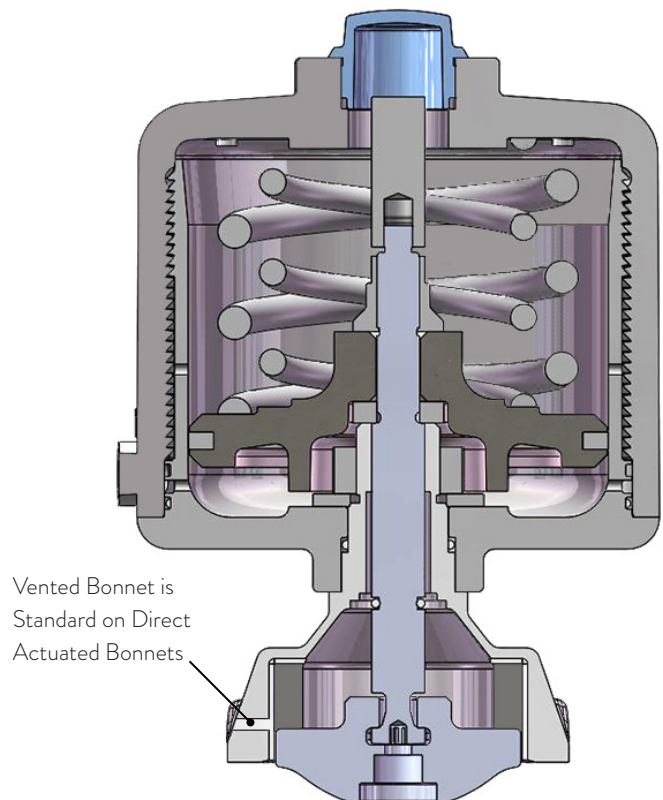
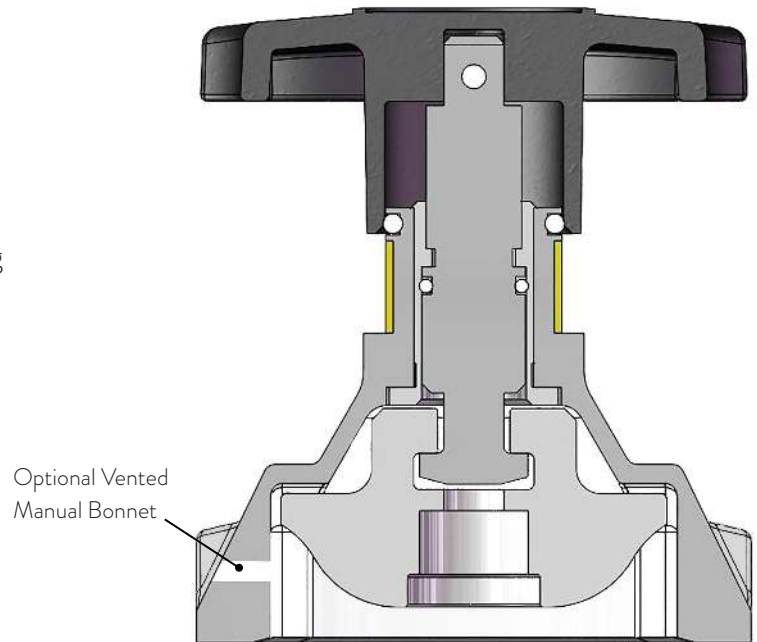

DIMENSIONS

Example drawings of some available configurations

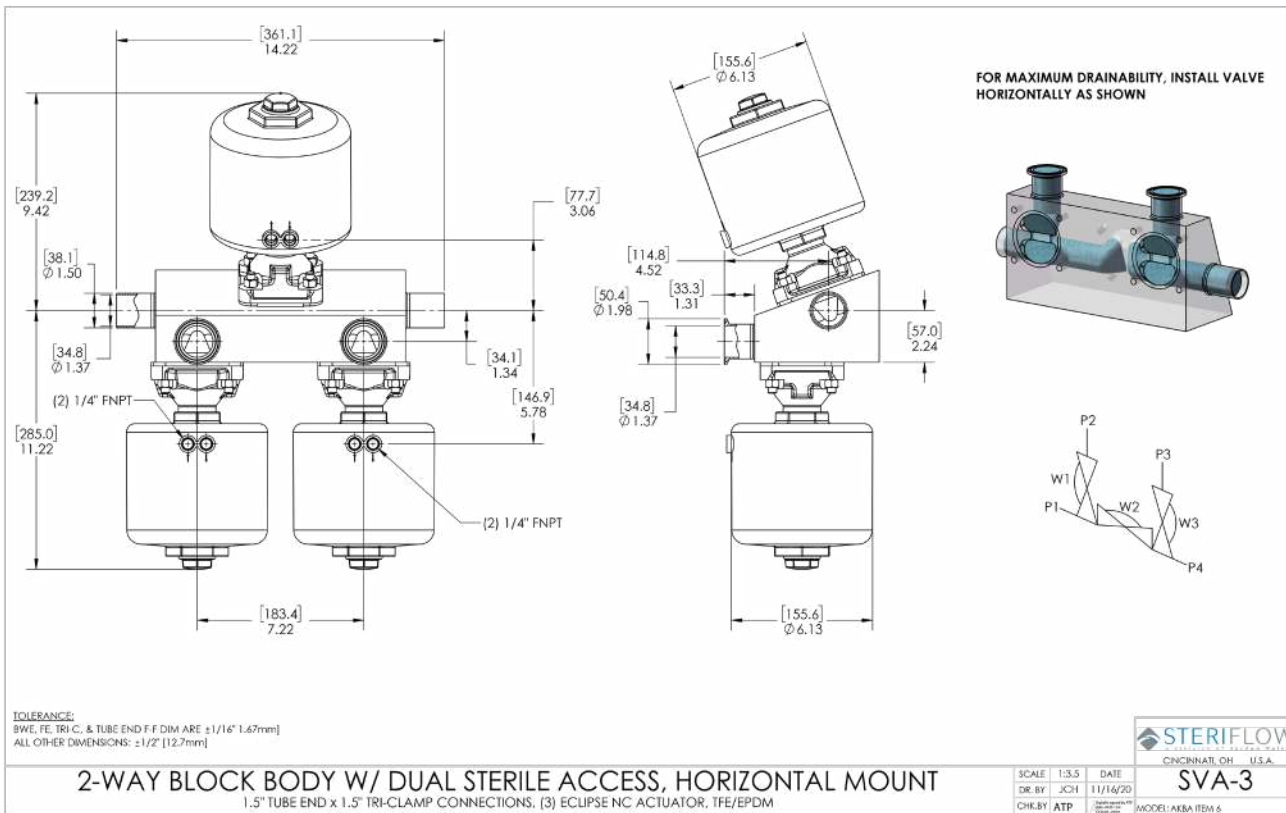
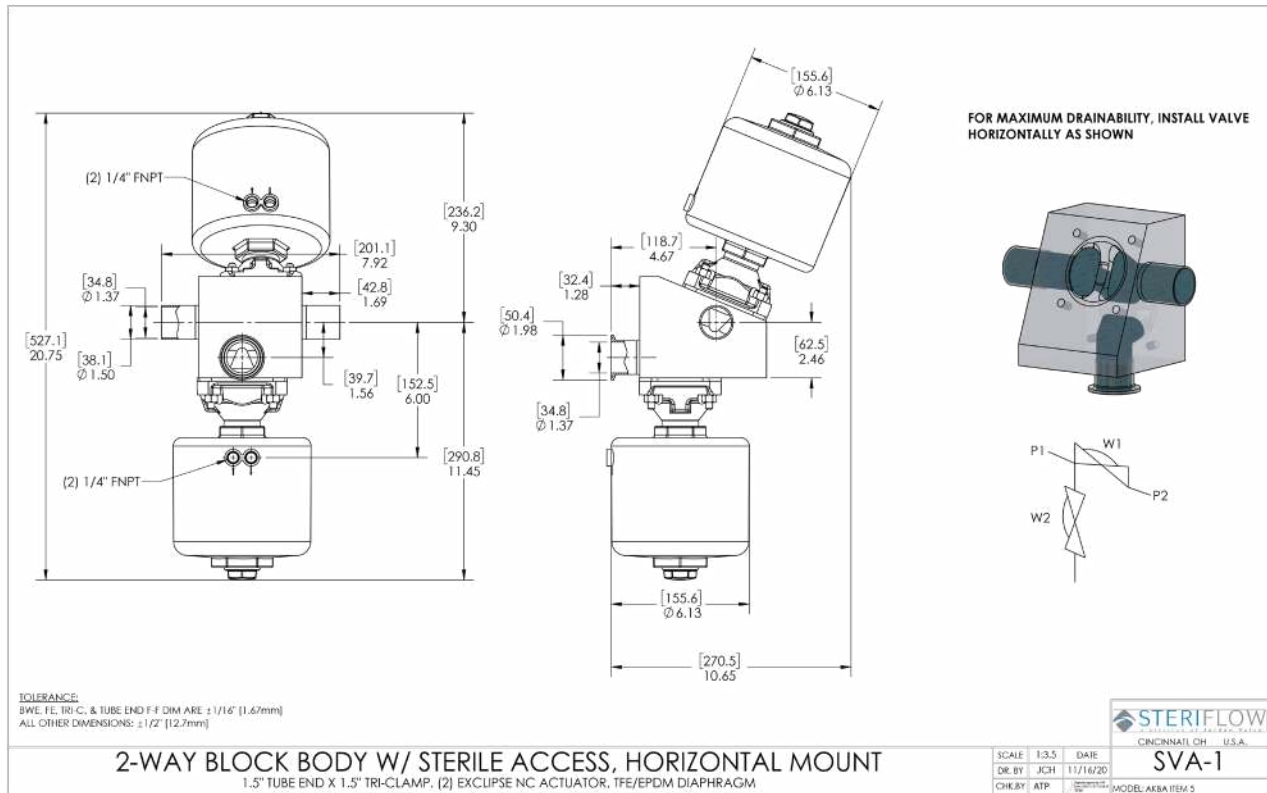

DIMENSIONS

Example drawings of some available configurations

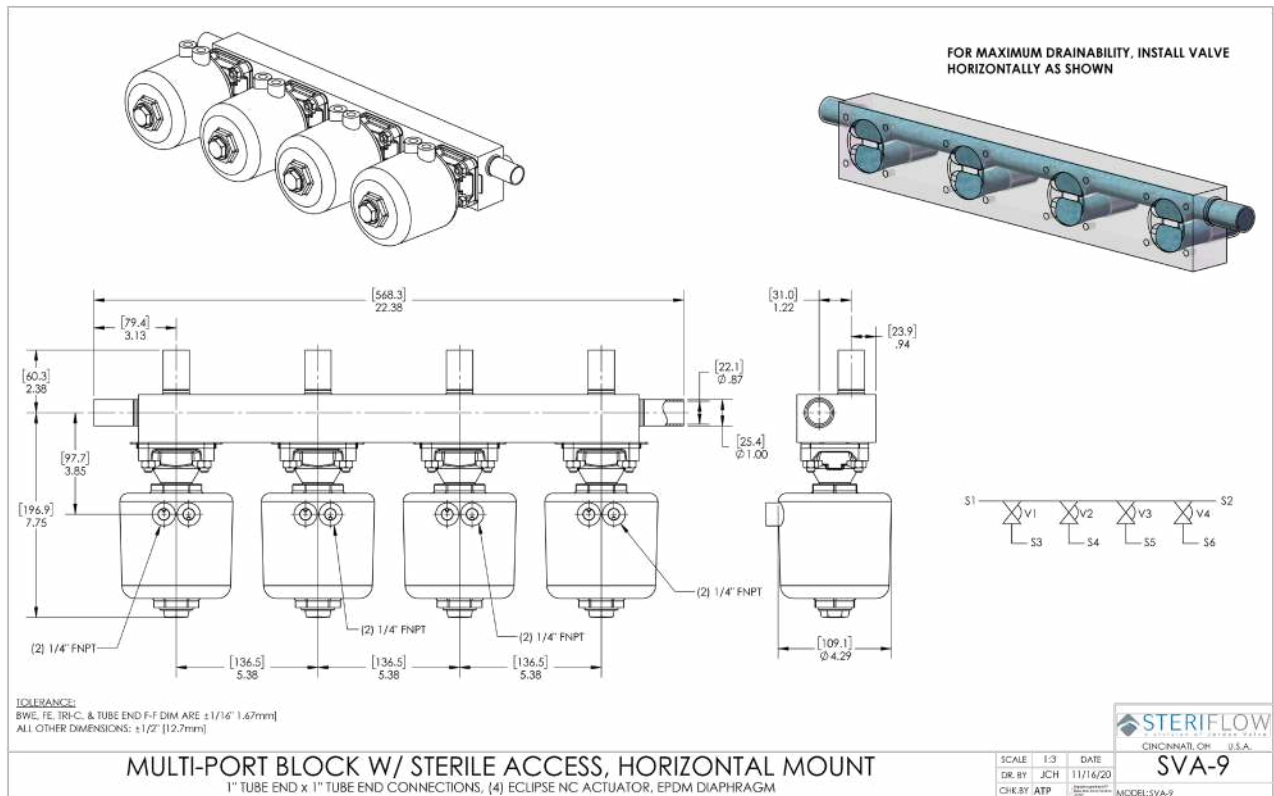
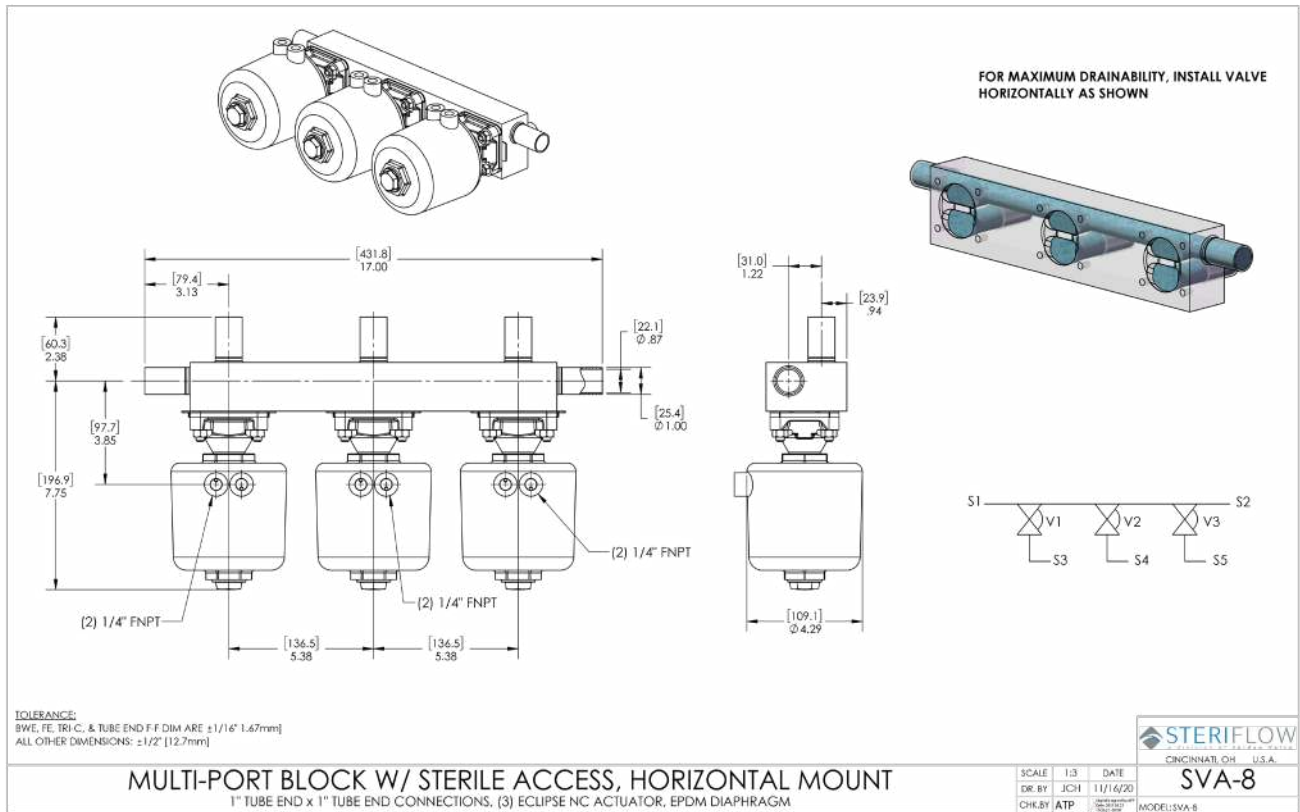

DIMENSIONS

Example drawings of some available configurations

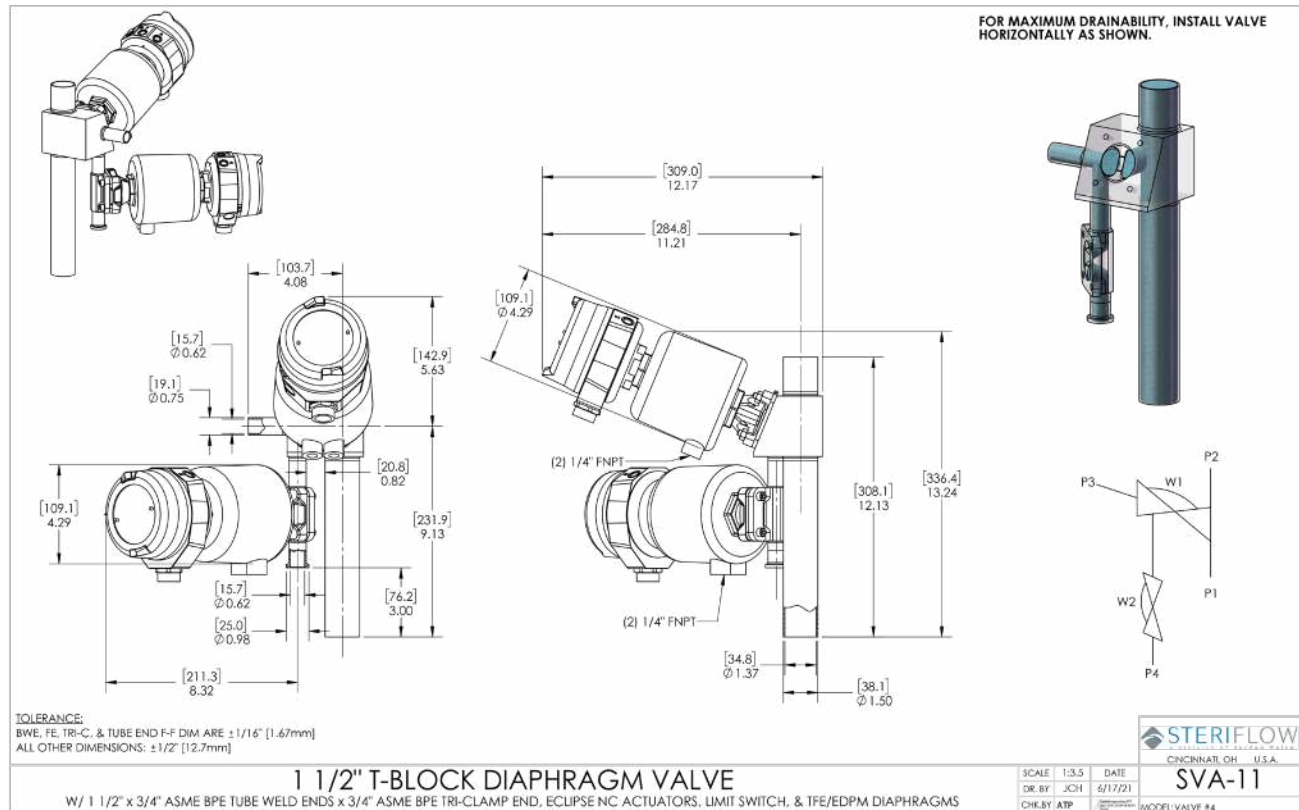
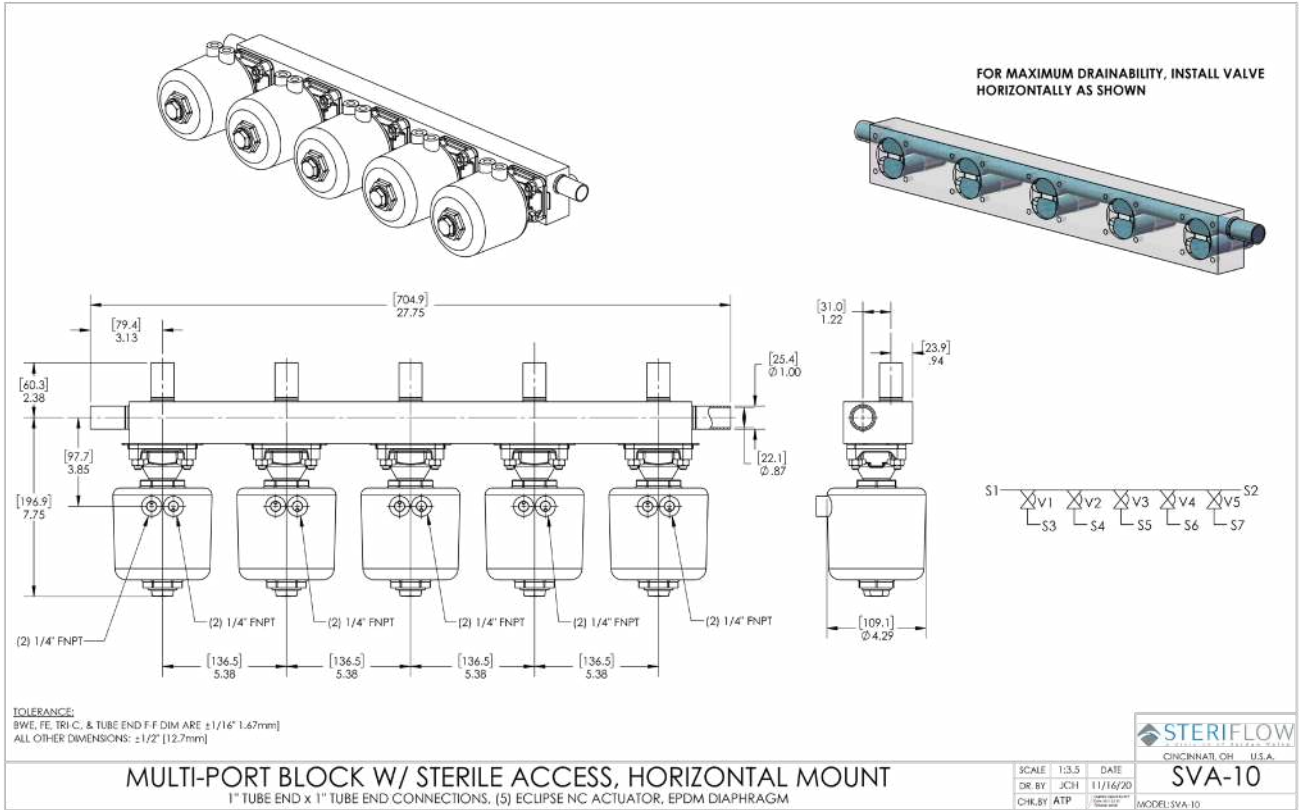

DIMENSIONS

Example drawings of some available configurations

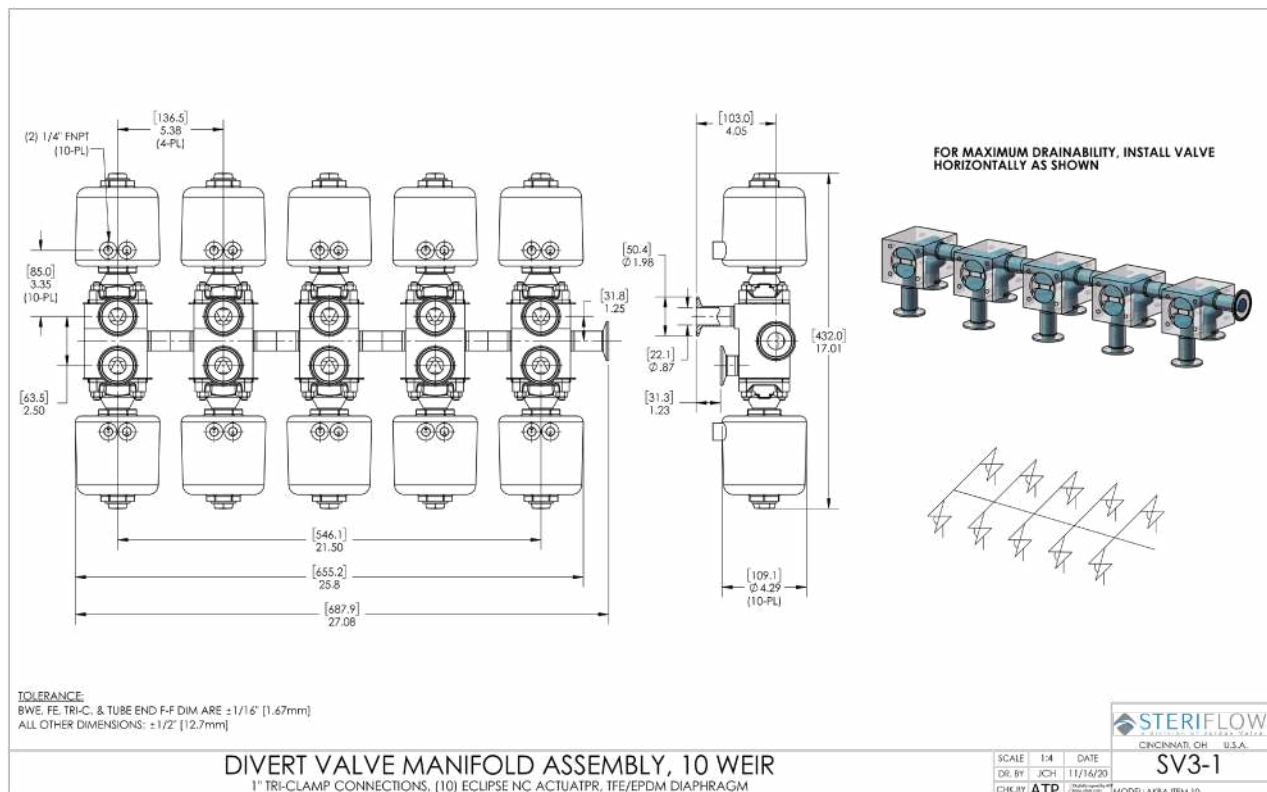
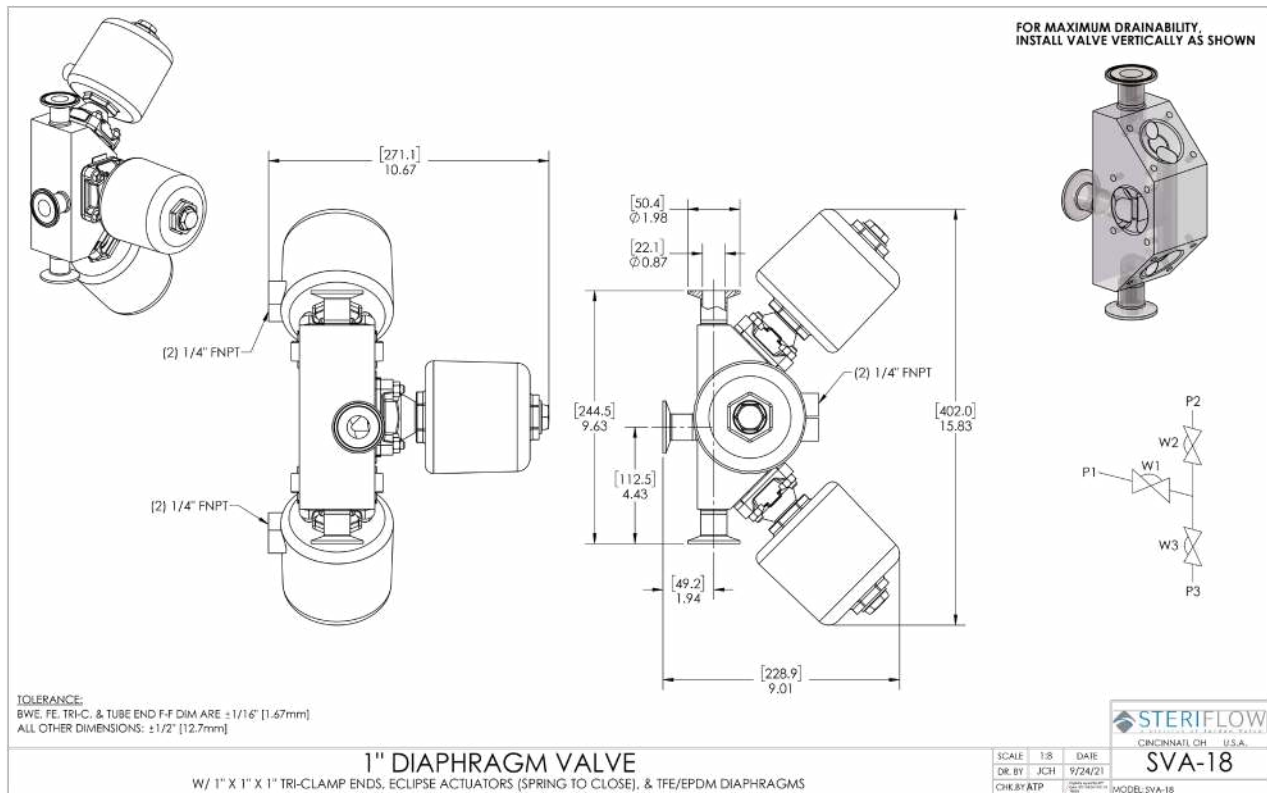

DIMENSIONS

Example drawings of some available configurations

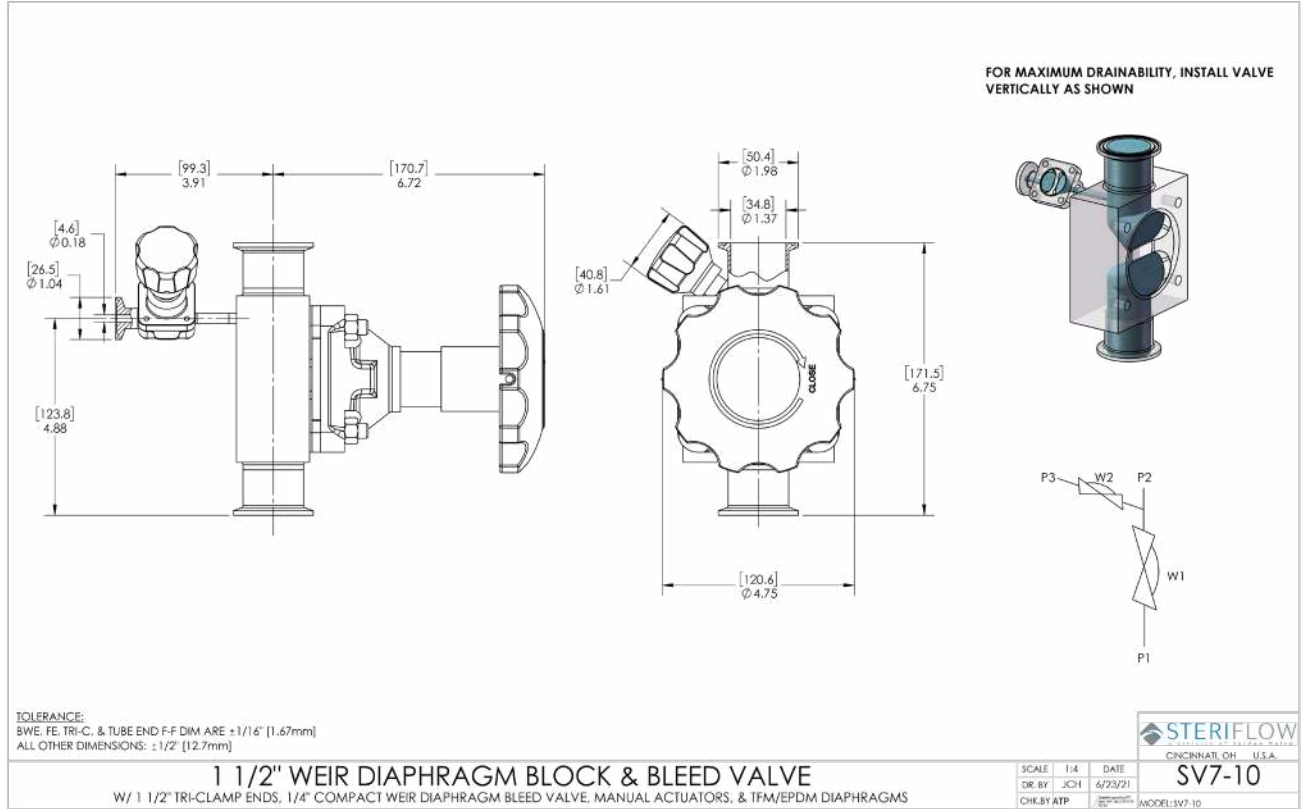

SANITARY DIAPHRAGM VALVES

Manual or Air Actuated Forged 2-way or Cast 2-way, Ported and Tandem valves. Barstock Zero Static T-Block, Point of Use T-Block, Divert Tank Bottom and Custom Block Body valves

FEATURES

- » Body & Trim Material: traceable ASME and DIN grade of 316L and Super-Austenitic Stainless Steel and Super Alloys readily available
- » Size Range: 1/4" - 4" (DN8 - DN100)
- » Manual or Air Actuated
- » Surface Finish:
 - Wetted Interior: ASME BBE SF5 20 Ra μ m (0.5 Ra μ m). Electropolish standard, SF4 and better finish available
 - Exterior: See individual model specifications
- » Diaphragm: All FDA, FDA/USP <88>, <87> Class VI, ADI-TSE Free
 - TFM/EPDM Backer
 - EPDM - Peroxide Cured

DOCUMENTATION





- » Steriflow Unicert; Certificate of Compliance for:
 - Material, including MTR's
 - Surface Finish
 - FDA/USP <88>, <87> Class VI
 - ADI/TSE Free cert available upon request
- » Each Unicert document lists the order's individual valve Serial/Suffix numbers and wetted component Heat numbers. MTR's for each Heat number follow on attached pages. The Serial numbers and Heat numbers are directly traceable to each individual valve
- » Valve Sizing information with quotation
- » Signed valve Leak Test report upon request

CERTIFICATION

- » CRN No.: 0C22893.5

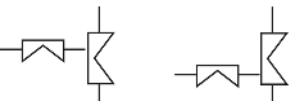
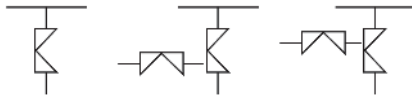
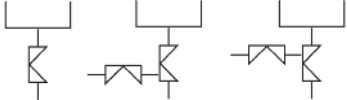
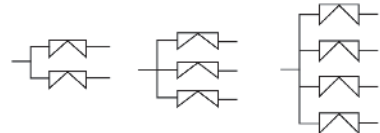

VALVE TYPE BY APPLICATION

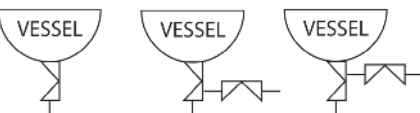
- » 2 - Ways 
- » Ported 
- » Tandem Access 
- » Zero Static T-Block 
- » Zero Static POU 
- » Divert Block 
- » Custom Blocks 
- » Tank Bottom 

GENERAL VALVE SPECIFICATIONS*

Line Size: 1/4" - 4" (DN8 - DN100)

End Connections: ASME BPE, DIN, ISO, Contact Factory

- » Tri-Clamp
- » Tube Weld End

Body Materials

- » Forgings: EN 10272:2000 GR 1.4435 316L standard
- » Bar Stock: ASME SA479 316L (UNS 31603) standard; EN 10272:2000 GR 1.4435, AL-6XN®, Hastelloy® C-22 and others readily available options

Diaphragm Material/Max Temperature: all diaphragms are FDA, USP <88> Class VI and <87> compliant and ADI-free

- » TFM/EPDM Backer / -14°F to 266°F (-26°C to 130°C) ≤300°F (150°C) at 50 psig (3,45 barg) max during SIP
- » EPDM Peroxide Cured / -14°F to 266°F (-26°C to 130°C) ≤300°F (150°C) at 50 psig (3,45 barg) max during SIP

Surface Finish: see individual valve specifications

Pressure at Maximum Temperature: 50 psig @ 300°F (3,45 barg @ 150°C)

Maximum Operating Pressure:

- » 1/4" - 1": 200 psi @ 100°F (13,8 bar @ 38°C)
- » 1-1/2" - 2": 175 psi @ 100°F (12,1 bar @ 38°C)
- » 2-1/2" - 4": 150 psi @ 100°F (10,3 bar @ 38°C)

Seat Leakage: ANSI FCI Class VI

FLOW COEFFICIENT CV (KV)

CONNECTION SIZE	VALVE DESCRIPTION	FLOW COEFFICIENT CV (KV)
1/4" - 1/2"	Compact valve/weir	1.16 (1,0)
1/2"	Any standard forged, barstock or cast body valve with catalog standard weir	5.2 (4,5)
3/4"		8.7 (7,52)
1"		13.9 (12,02)
1-1/2"		34.8 (30,1)
2"		59.7 (51,6)
3"		185 (160)
4"		272 (235)

BONNET/ACTUATOR SPECIFICATIONS*

Manual Bonnet Assembly:

- » Available for valve sizes: 1/2" - 4" (DN15 - DN100)
- » Closing Stop: Adjustable
- » Bright visual position indicator
- » Options: Contact factory for proximity switches, locking devices and stroke limiter

Bonnet Materials

- » Bonnet: Electropolished Stainless Steel
- » Compressor: Stainless Steel
- » Insert: Brass
- » Thrust Washer: PTFE
- » Compressor Pin: Stainless Steel
- » Indicator: Polyolefin
- » Bushing: Brass
- » Stem: Stainless Steel
- » Handwheel: PPS (1/4" - 2"); Stainless Steel (2-1/2" - 4")

Air Actuated Bonnets:

- » Available for sizes: 1/2" - 2" (DN15 - DN50) standard; 3" & 4" (DN80 & DN100) optional
- » Air Actuator Materials: Polyamide, Stainless Steel, Stainless Steel base standard for all configurations
- » Actuator Seal: Actuator springs and seals can be replaced without exposing process
- » Orientation: Swivel feature allows 360° orientation of air inlet
- » Air Connections: NPT Stainless Steel base standard for all configurations
- » Function: Change from Normally Open or Normally Closed by inverting the actuator housing
- » Control System Interface: Available with optional switch packages for on/off control or with positioners for flow control and modulation

* Most valves meet all of these general features and specifications. However, sizes may vary depending upon product selected. See individual product page for specific details about each model.