

---

# PRESSURE VACUUM VALVE

---

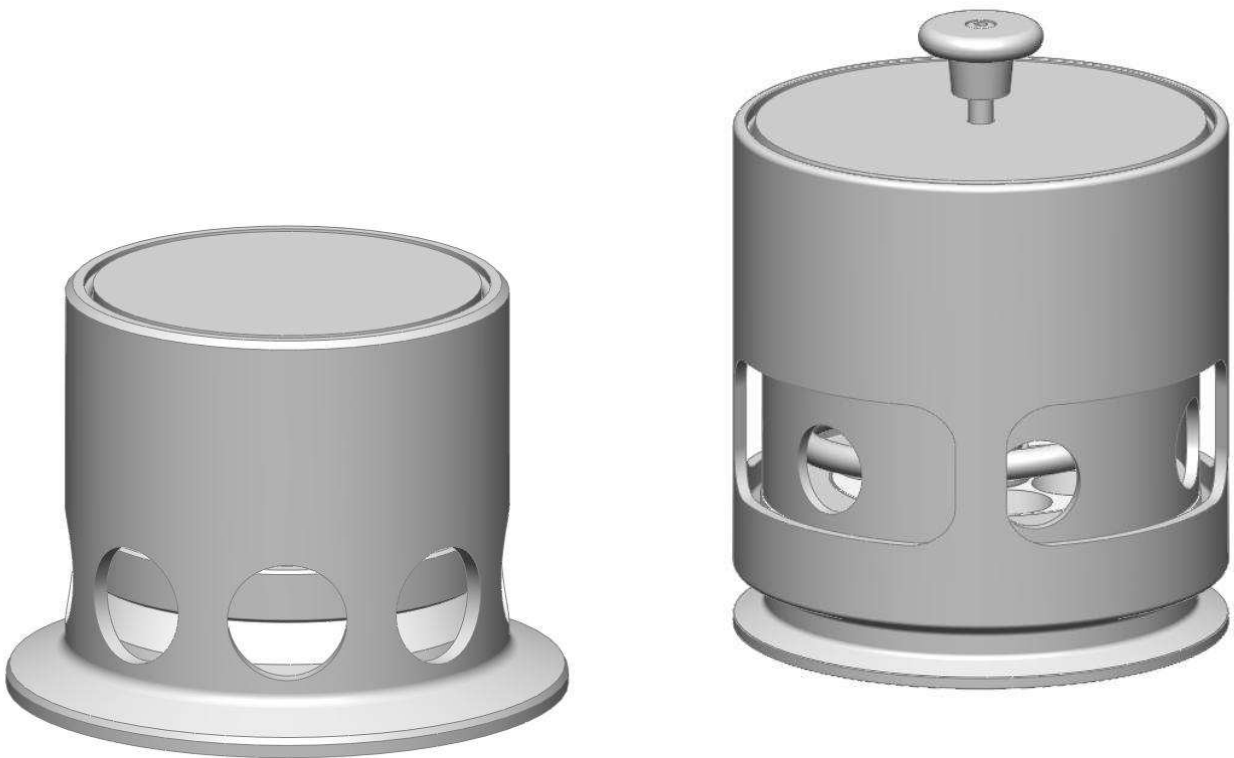

[www.definox.com](http://www.definox.com)

**TABLE OF CONTENTS**

<b>1 CHANGE MANAGEMENT</b>	<b>3</b>
<b>2 SAFETY</b>	<b>4</b>
2.1 IMPORTANT INFORMATION	4
2.2 GENERAL INFORMATION	4
<b>3 INTRODUCTION</b>	<b>5</b>
<b>4 DISMANTLING THE 2" AND 2"1/2 PRESSURE VACUUM VALVE</b>	<b>6</b>
4.1 DISMANTLING THE 2" AND 2"1/2 VALVE	6
4.2 DISMANTLING THE VACUUM/SEAT VALVE ASSEMBLY	7
<b>5 DISMANTLING THE 4" PRESSURE VACUUM VALVE</b>	<b>8</b>
5.1 DISMANTLING THE 4" VALVE	8
5.2 DISMANTLING THE VACUUM/PRESSURE VALVE ASSEMBLY	9
<b>6 REASSEMBLING THE VALVES</b>	<b>10</b>
6.1 INTRODUCTION	10
6.2 REASSEMBLING THE 2" 2"1/2 PRESSURE VACUUM VALVE	10
6.3 REASSEMBLING THE 4" PRESSURE VACUUM VALVE	11
<b>7 PARTS</b>	<b>12</b>
7.1 DN2" AND DN 2"1/2 PRESSURE VACUUM VALVE	12
7.2 4" PRESSURE VACUUM VALVE	13
7.3 LIST OF PARTS FOR PRESSURE VACUUM VALVES	14

## 1 CHANGE MANAGEMENT

CHANGES	INDEX	DATE	PAGE(S)	INITIALS
New version	1	September 06	/	R. GABORIT
Update	2	September 08	/	G. ANDRE
Update of snap-ring [14] for DN4"	3	September 09	14	N. CROZIER

## 2 **SAFETY**

### 2.1 **IMPORTANT INFORMATION**

Always read the maintenance notice before manipulating the pressure vacuum valve.



**DANGER!**

Failure to observe these instructions can result in serious bodily injury or loss of life.



**CAUTION!**

This can also result in less serious injuries or damage to the equipment.



**DANGER!**

Electricity can result in serious bodily injury or loss of life.



**CAUTION!**

This can also result in less serious injuries or damage to the equipment.

### 2.2 **GENERAL INFORMATION**



**NOTE**

The following advice is given to ensure optimum use of the equipment.

- The tasks must be performed in the order specified.

---

---

**MAINTENANCE NOTICE Pressure/vacuum valve.**

---

---

### **3 INTRODUCTION**

The disassembly process for pressure/ vacuum valves is carried out in a single step:

This operation enables access to the seals (Changing the seals).

This is a straightforward procedure and can be performed on-site as it does not present any particular problems.

This is the case in the majority of maintenance operations on this type of valve.



**DANGER!**

**CAUTION:** This operation must be performed using a special tool ensuring that the necessary precautions are taken (**STRESSED SPRING**).



**NOTE**

**NOTE:** After carrying out any maintenance work on DEFINOX products it is essential that you check the correct function of the equipment concerned : tightness, pressure, etc...

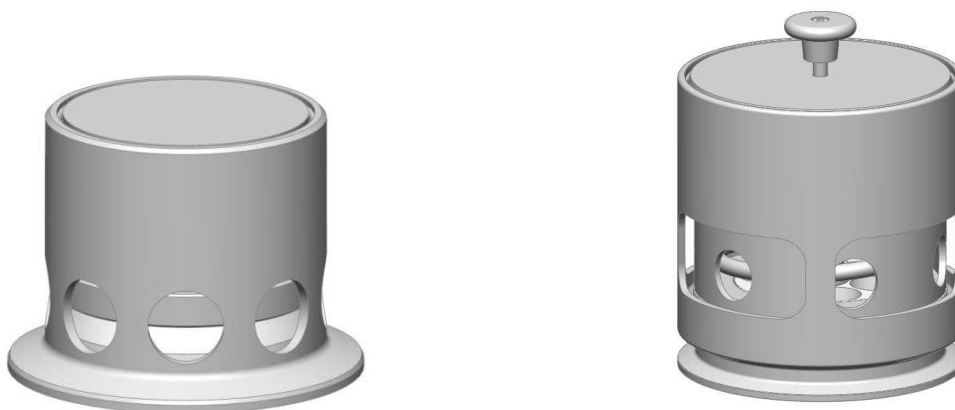

## 4 DISMANTLING THE 2" AND 2"1/2 PRESSURE VACUUM VALVE

### 4.1 DISMANTLING THE 2" AND 2"1/2 VALVE



**CAUTION:** This is a hazardous operation if performed without using the correct tools. We recommend using a hydraulic press or a tool of the type shown in the diagram opposite (this tool must be made to accommodate a spring expansion of 60 mm).

With the valve placed vertically:

- Push down the cap [10] to remove the snap-ring.
- Remove the snap-ring [14] from its recess using a small screwdriver.
- Release the pressure to allow the cap to rise back.
- Remove the cap and the spring [17].
- Remove the valve guide [6] and the vacuum/seat valve assembly [3-4] from the valve body [1] and the O-ring [19].

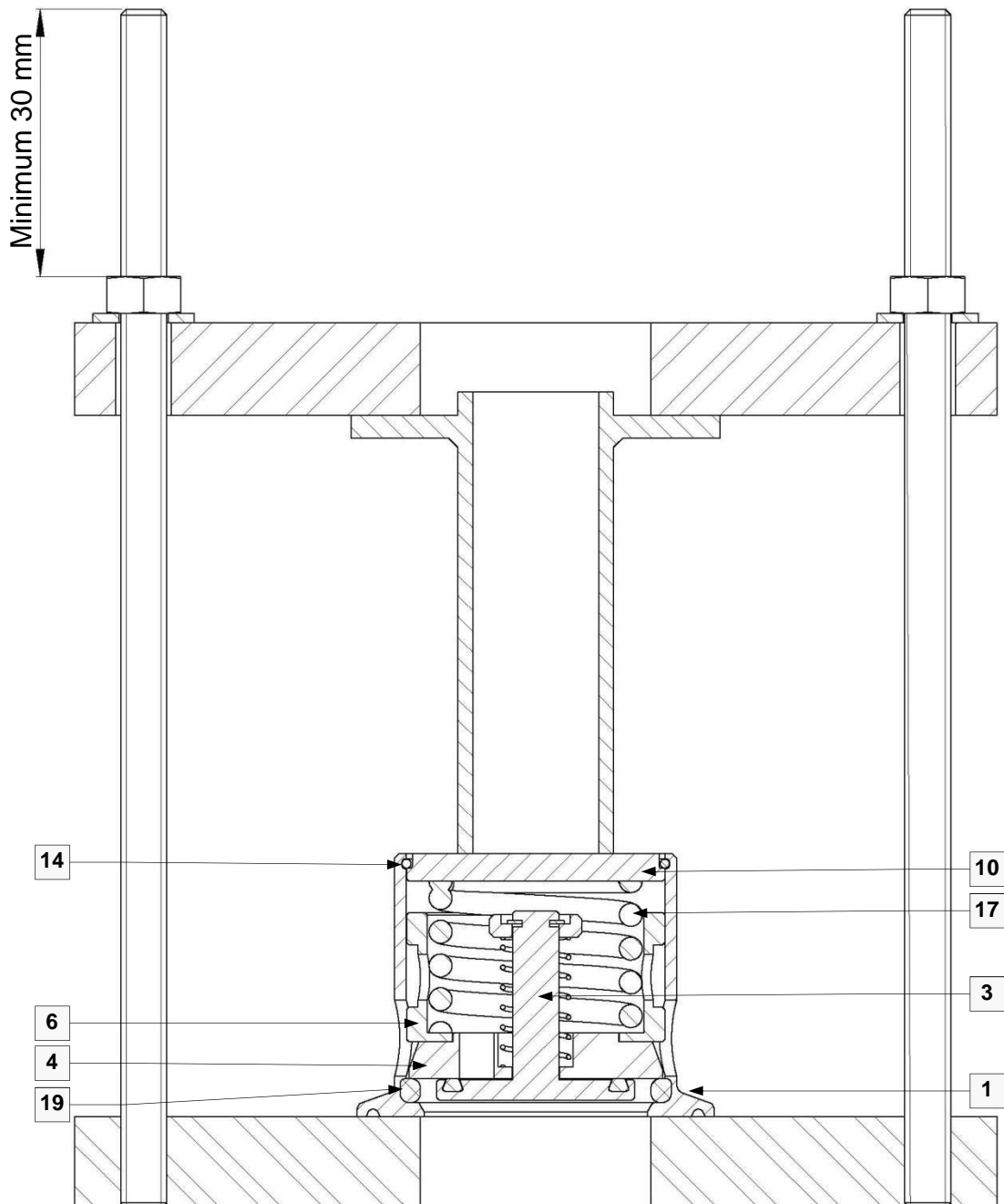

**4.2 DISMANTLING THE VACUUM/SEAT VALVE ASSEMBLY**

With the vacuum/seat valve assembly placed vertically:

- Push down the washer [12] to remove the stop washer [13] from the vacuum valve [3] using a small screwdriver.
- Release the pressure to allow the washer [12] to rise back so that the spring [16] can be removed.
- Remove the seat [4].
- Remove the body O-ring [19] from the vacuum valve [3].

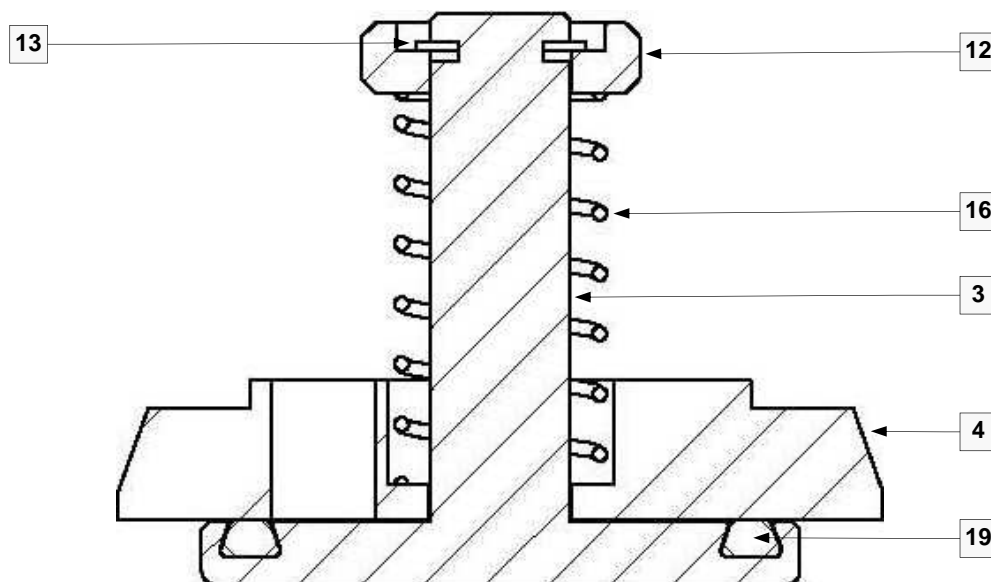

## 5 DISMANTLING THE 4" PRESSURE VACUUM VALVE

### 5.1 DISMANTLING THE 4" VALVE



**CAUTION:** This is a hazardous operation if performed without using the correct tools. We recommend using a hydraulic press or a tool of the type shown in the diagram opposite (this tool must be made to accommodate a spring expansion of 150 mm).

With the valve placed vertically:

- Remove the screw [20] to extract the end of the valve [11].
- Push down the end of the pressure valve [7] to remove the snap-ring.
- Remove the snap-ring [14] from its recess using a small screwdriver.
- Release the pressure to allow the end of the pressure valve to rise back up.
- Remove the end of the pressure valve, the spring [17], the pressure valve piston [5] and the ring [22].
- Remove the vacuum/pressure valve assembly [3-2] from the valve body [1] and the O-ring [19].

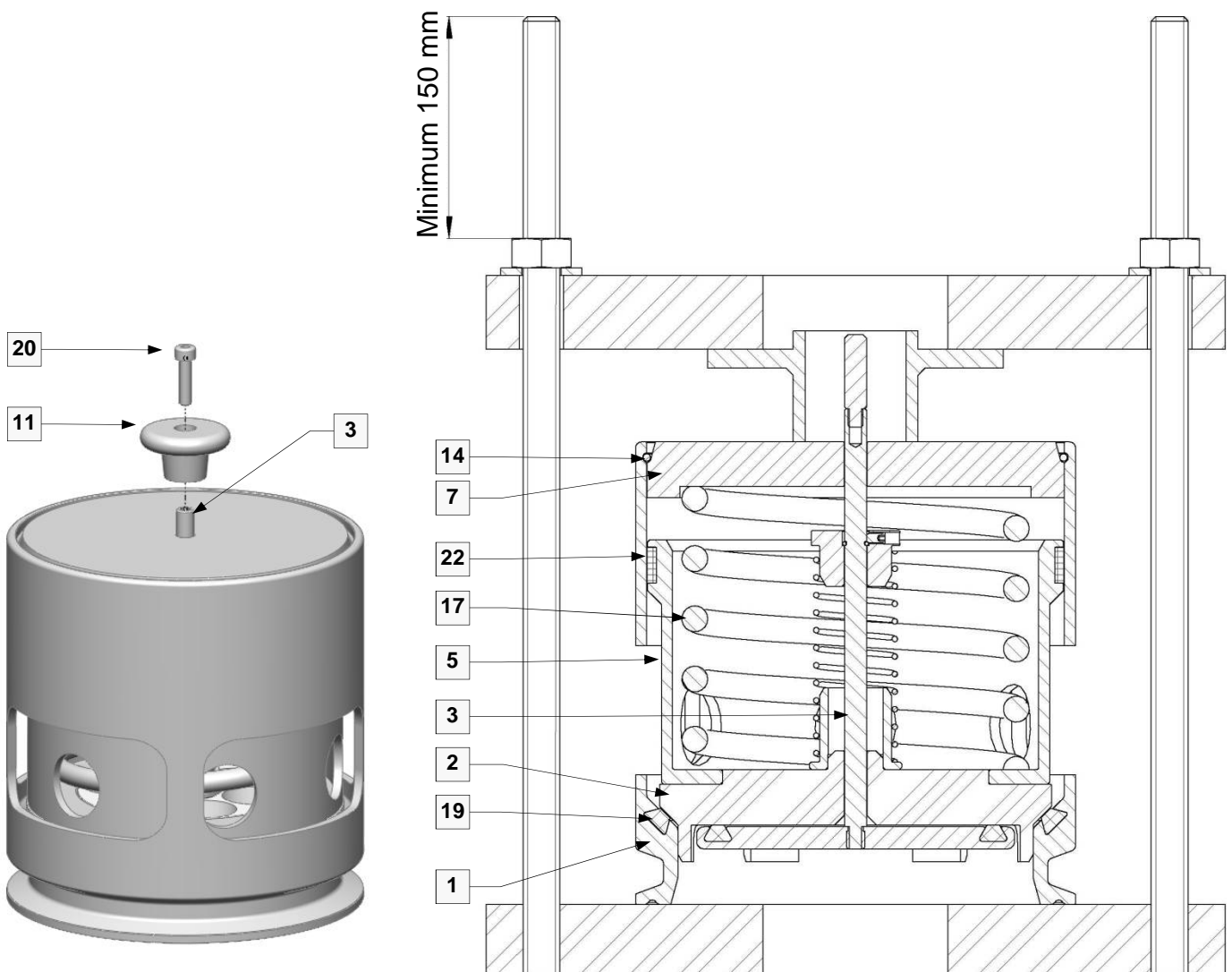



## 5.2 DISMANTLING THE VACUUM/PRESSURE VALVE ASSEMBLY

With the vacuum/pressure valve assembly placed vertically:

- Release the STHC screw [21], push down the pressure valve guide [9] to remove the snap-ring [15] from the vacuum valve [3] using a small screwdriver.
- Release the pressure to allow the pressure valve guide [9] to rise back up so that the spring [16] and vacuum valve seat [8] can be removed.
- Remove the pressure valve [2].
- Remove the O-ring [18] from the vacuum valve [3].

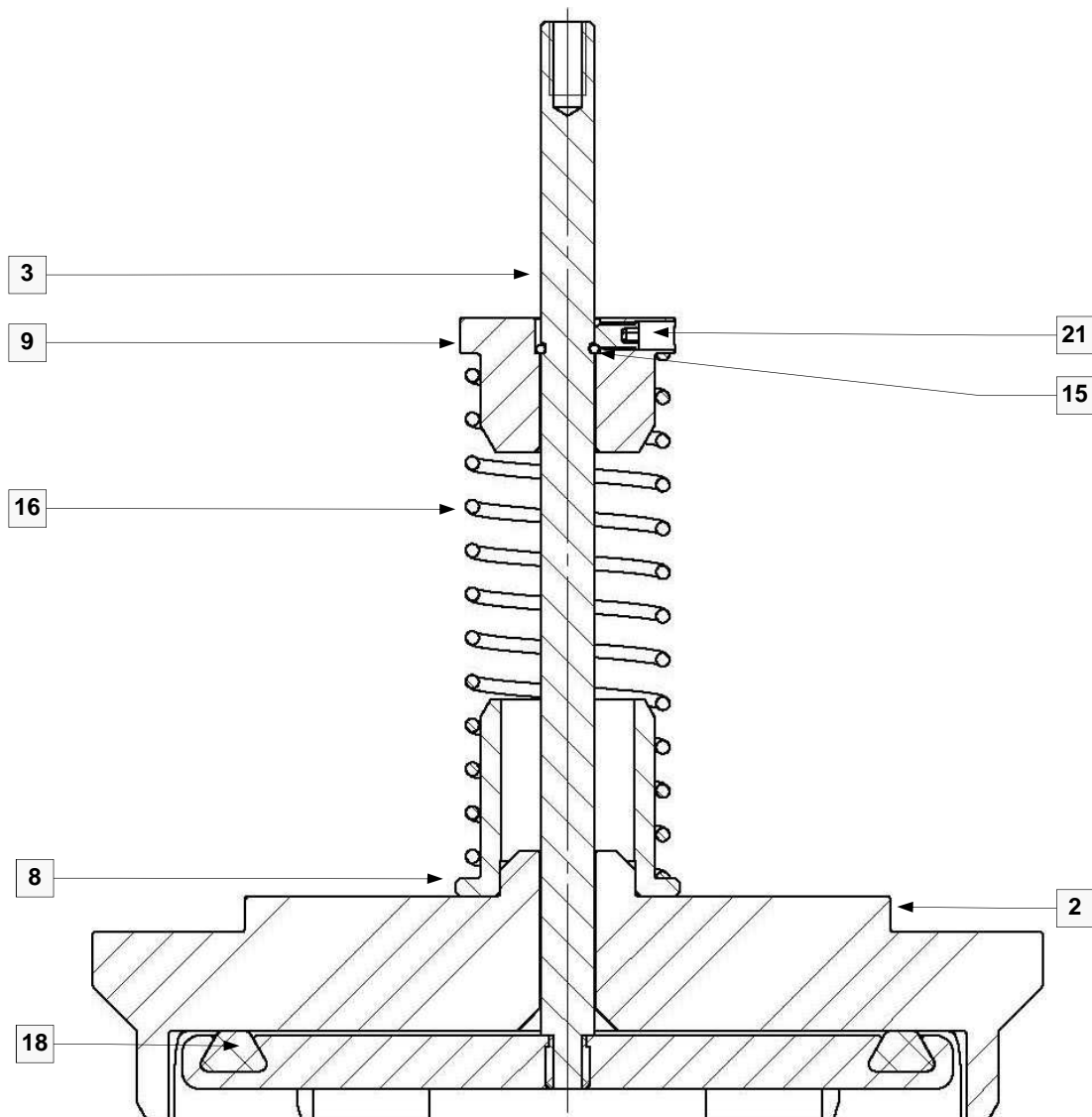

## 6 REASSEMBLING THE VALVES

### 6.1 INTRODUCTION

Our valve components are listed and referenced in the “Parts catalogue” section of our folder and our CD-ROM, together with the information necessary for ordering your spare parts.

### 6.2 REASSEMBLING THE 2" 2"1/2 PRESSURE VACUUM VALVE

This procedure is performed in the reverse order to dismantling. However, it is necessary to take into account the following information:

- Before reassembling the parts, ensure that the assembly is lubricated with an appropriate lubricant (water-resistant and temperature-resistant food grade grease → Example: 4025 H1 QUINPLEX by Lubrication Engineers). Ensure that the grease used is compatible with the elastomer seals.
- Check that the cap [10] is properly positioned in the valve body [1].
- Ensure that the snap-ring [14] is properly positioned in the recess of the valve body [1] before releasing the pressure.
- Activate the valve to check that it operates correctly.

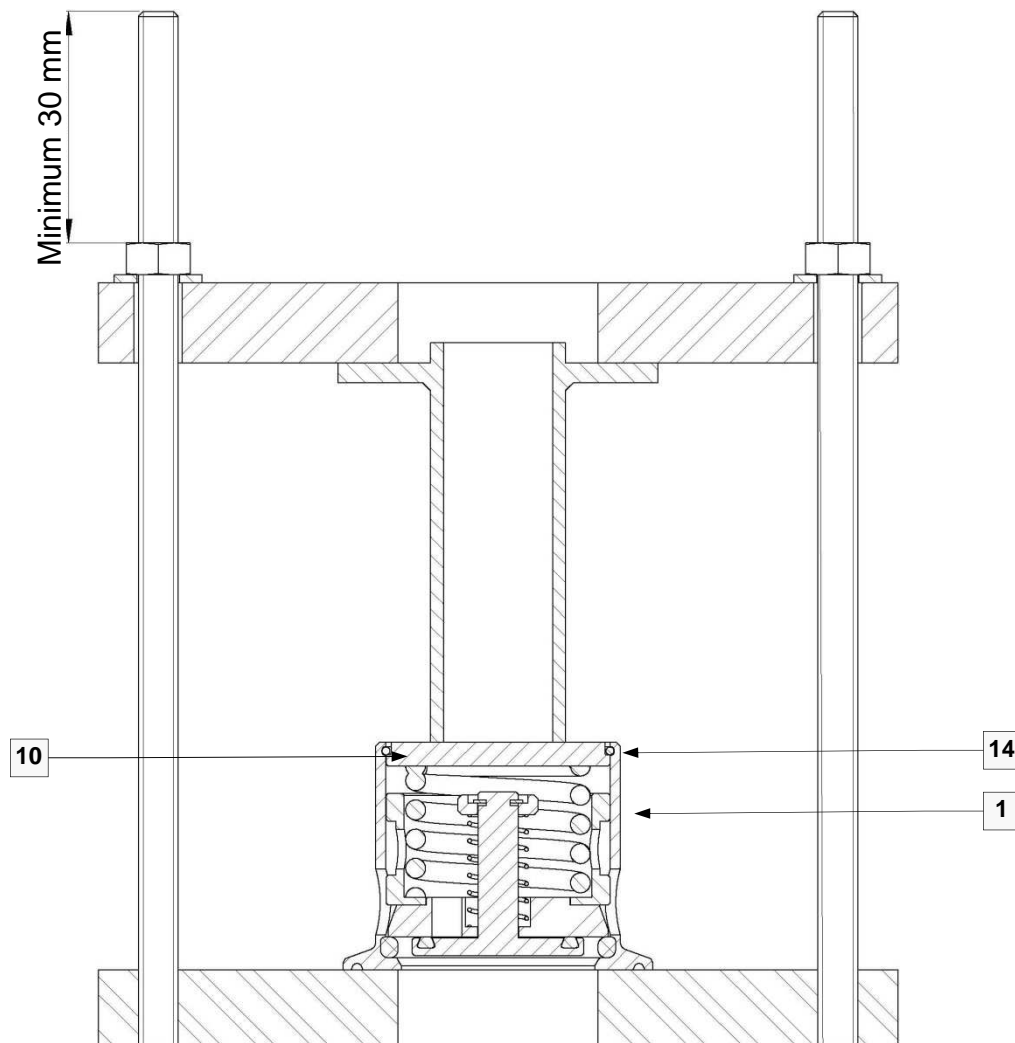

**6.3 REASSEMBLING THE 4" PRESSURE VACUUM VALVE**

This procedure is performed in the reverse order to dismantling. However, it is necessary to take into account the following information:

- A guide pin centred on the vacuum valve stem [3] ensures that the end of the pressure valve [7] is properly centred in the body of the valve [1].
- Before reassembling the parts, ensure that the assembly is lubricated with an appropriate lubricant (water-resistant and temperature-resistant food grade grease → Example: 4025 H1 QUINPLEX by Lubrication Engineers). Ensure that the grease used is compatible with the elastomer seals.
- Ensure that the snap-ring [14] is properly positioned in the recess of the valve body before releasing the pressure.
- Activate the valve to check that it operates correctly.

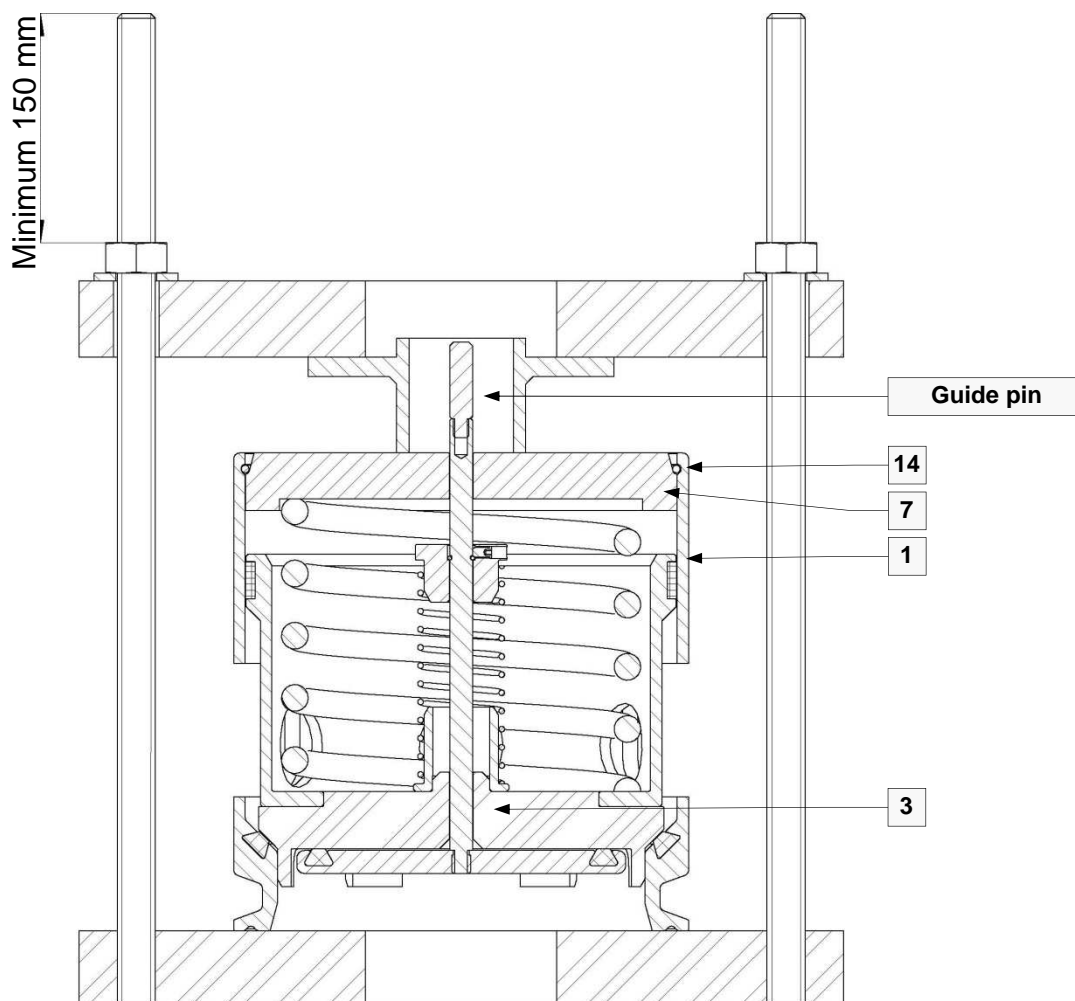

**7 PARTS**

**7.1 DN2" AND DN 2"1/2 PRESSURE VACUUM VALVE**

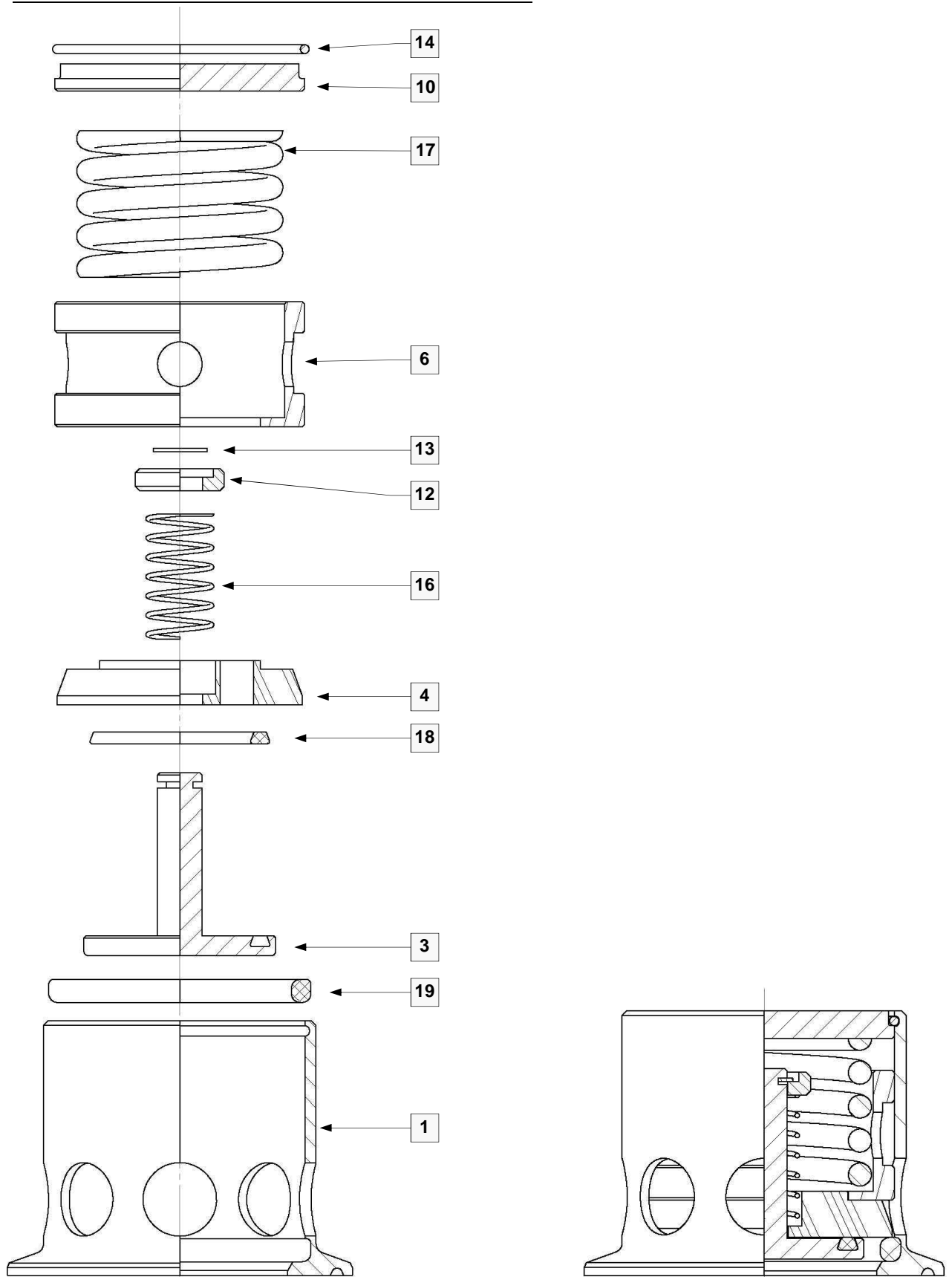

7.2 4" PRESSURE VACUUM VALVE

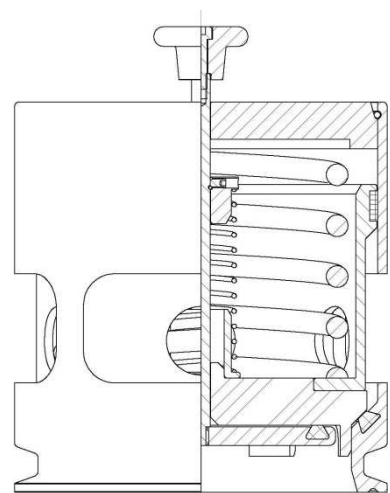
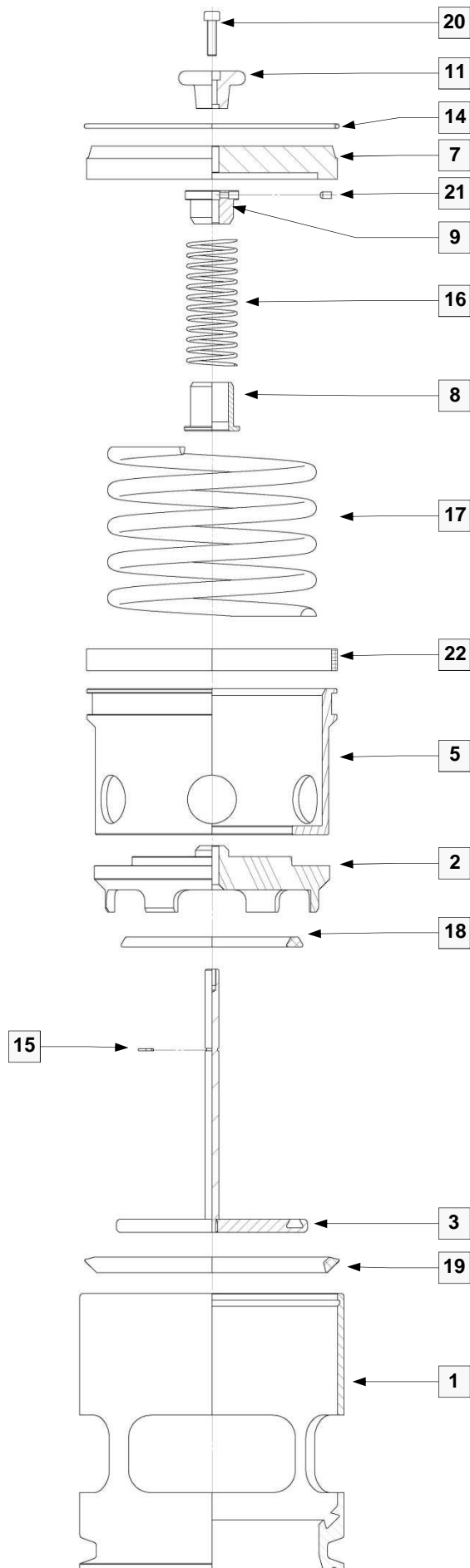

**7.3 LIST OF PARTS FOR PRESSURE VACUUM VALVES**

Ref	Part name	Qty	DN 2"	DN 2"1/2	DN 4"
01	Valve body	1	7201706	7201731	7201385
02	Pressure valve plug	1			7201389
03	Vacuum valve plug	1	7201708	7201708	7201391
04	Seat	1	7201709	7201709	
05	Pressure vacuum valve piston	1			7201390
06	Valve guide	1	7201758	7201758	
07	Pressure vacuum valve base	1			7201388
08	Vacuum valve plug seat	1			7201396
09	Guide Pressure vacuum valve	1			7201392
10	Cap	1	7201237	7201237	
11	Pressure vacuum valve end	1			7201386
12	Washer	1	7201401	7201401	
13	Stop washer	1	7503028	7503028	
14	Snap-ring	1	7007764	7007764	7007889
15	Pressure vacuum valve stem ring	1			7007788
16	Vacuum spring	1	7007866	7007866	7007814
17	Pressure spring	1	See attached table		
18	Plug seal	1	7006094	7006094	7006073
19	Body seal	1	7380612	7380612	7006095
20	Vacuum valve CHC screw	1			7380341
21	Pressure vacuum valve guide STHC screw	1			7006848
22	Pressure vacuum valve piston ring	1			7009983

Diameter			DN2"	DN2"1-2	DN4"	
Ref	Part name	Qty	Reference for spring / pressure in bar			
17	Pressure spring	1	7007816	0.7	7007824	0.2
			7007817	1	7601117	0.5
			7007818	1.4	7007808	1
			7007819	1.8	7007803	1.3
			7007869	2	7007794	1.7
			7007820	2.5	7007789	2
			7020021	3	7007829	2.8

[www.definox.com](http://www.definox.com)

**FRANCE**

DEFINOX SAS  
3 Rue des Papetiers - Z.A.C de Tabari 2  
44190 CLISSON - France  
Tel : +33 (0)2 28 03 98 50 Fax : +33 (0)2 28 03 88 00  
[info@definox.com](mailto:info@definox.com)

**USA**

DEFINOX INC.  
16720 W. Victor Road  
New Berlin – WISCONSIN 53151 – USA  
Tel : (1) 262 797 5730 - Fax : (1) 262 797 5735  
[lbuckett@definox-usa.com](mailto:lbuckett@definox-usa.com)

**CHINA**

DEFINOX Beijing Stainless Steel Equipment Ltd  
No 18 Anningzhuang East Road – HAIDIAN District  
BEIJING 100085 – CHINA  
Tel : (86) 10.6293.4909 - Fax : (86) 10.6293-4835  
[lk@definox.com.cn](mailto:lk@definox.com.cn)

The product specifications of this document are indicative and may be modified according to technological developments.  
None of the photographs, designs and diagrams are binding.

This document is our property. It may not be copied, reproduced, modified or translated without our express authorization.  
DEFINOX is a registered trademark.